



| **Generator** LPG/NG 20 KW **Liquid Cooled**



**Elios Generator LPG/NG 20KW Liquid Cooled**

**120/240VOC, 1ph, 60HZ - 3600rpm**

**Installation Manual**

# Installer's Guide Home Standby Generator



EliosGen20KH-120/240

**Note:**

*Graphics in this document are for representation only.*

*Actual model may differ in appearance.*

***Strongly recommends that only factory-authorized distributors or dealers install and service the generator***



## Installation, Maintenance and Repair Manual For licensed authorized personnel only.

Read all instructions carefully before installation.

**⚠ WARNING:** Only qualified technicians and contractors should perform the installation.

**NOT INTENDED FOR USE IN CRITICAL LIFE SUPPORT APPLICATIONS!**

### Save all instructions!

It is recommended that Serial Number # be recorded for future warranty, parts, and service needs. It can be located inside the back-panel on the stamped ID plate or on the outside of the original shipping carton.

Engine ID # \_\_\_\_\_

Controller Password \_\_\_\_\_

**KEEP THIS MANUAL WITH THE UNIT TO TRANSFER  
WITH THE OWNER SHIP OF THE EQUIPMENT.**

## TABLE OF CONTENTS

Introduction .....	5
Operation & Maintenance .....	6
Common Hazards and Electrical Hazards .....	7
Fire Hazards, Explosion Hazards and Standards Index .....	8
Uncrating and Initial Inspection and NEC Requirements .....	9
First Step, Location and Site Preparation .....	10
Lubrication System .....	12
Cooling System .....	13
Fuel Selection and conversion from NG to LPG .....	13
Installing and Connecting Gas Lines .....	14
Transfer Switch Wiring Diagram .....	16
Battery Connection .....	17
Generator Electrical Connections .....	18
Controller Key Functions Operation .....	19
Auto Start/Stop .....	21
Manual Start/Stop .....	21
Emergency Start Up .....	22
Protection .....	22
Shut Down Alarm .....	25
Parameter Settings .....	27
Typical Application .....	28
Wiring Connection .....	29
ATS Installation .....	30
Typical ATS Wiring Diagram .....	33
Testing .....	34
Circuit Coverage .....	34
Electrical Connections .....	34
Functional Testing .....	36
Maintenance of Generator .....	38
Cooling System Maintenance .....	39
Radiator Maintenance .....	41
Engine Maintenance .....	43
Common Fault and Repair Methods .....	44
Engine, Primary Parts and Structure .....	49
Generator Alternator and Specifications .....	50
Enclosure Parts .....	52
Common Formulas .....	53
Common Maintenance Parts for Generator .....	54
Additional Trouble Shooting Procedures .....	55

## INTRODUCTION

Thank you for choosing an Elios generator. This manual provides you with extremely important information about the installation, operation, and maintenance of the generator system. If you have any questions about our products, parts, propane products, warranty or service questions, or need professional installation services, please call 1-514-863-7097.

Before using this generator, you are advised to read the manual in its entirety and fully understand its contents. This generator utilizes an automotive 998cc, 4-cylinder liquid cooled, gas engine. The design was selected because it has been in service for over 20 years with millions of dependable hours and miles in various applications. This ensures and provides the performance needed for long-term, dependable power output. Through constant development, this unit has advantages that several similar sized products do not offer. Such as, automotive grade engine, liquid-cooled radiator system, powder coated steel/composite exterior housing, automotive grade muffler for silent operation, electronic speed control system, 200amp automatic transfer switch (ATS) optional, Sincro-low distortion alternator for all electronic devices, SmartGen intelligent control system in two programmable languages and multi-function capability's, GSM digital monitoring system (optional), Cold weather kit for extreme cold temperature starts (optional). For optional equipment contact our customer service department at 1-514-863-7097.

Due to continual improvements and a commitment to offer the latest technology, service and warranty, this manual may differ slightly from the actual object. Contact Elios with any questions: 1-514-863-7097.

	<p style="text-align: center;"><b>⚠ WARNING</b></p> <p>This product may contain a chemical known to the State of California to cause cancer or birth defects or other reproductive harm.</p> <p>Este producto puede contener un producto químico conocido en el estado de California como causantes de cáncer o de defectos de nacimiento u otros daños reproductivos.</p> <p>Ce produit peut contenir un produit chimique connu dans l'État de Californie pour causer le cancer ou des malformations congénitales ou autres.</p>
	<p style="text-align: center;"><b>⚠ WARNING!</b></p> <p>Using a generator inside CAN KILL YOU IN MINUTES.</p> <p>Generator exhaust contains carbon monoxide. This is a poison that you cannot see or smell.</p> <p>NEVER use inside a home or garage, EVEN IF doors and windows are open.</p> <p>Only use OUTSIDE and far away from windows, doors and vents.</p> <p>Avoid other generator hazards, READ MANUAL BEFORE USE</p>
	<p style="text-align: center;"><b>⚠ ¡ADVERTENCIA!</b></p> <p>Usar un generador en el interior puede MATAR EN CUESTIÓN DE MINUTOS.</p> <p>Escape del generador contiene monóxido de carbono. Este es un veneno que no se puede ver ni oler.</p> <p>No utilice nunca dentro de la casa o en el garaje, incluso si las puertas y ventanas están abiertas.</p> <p>Utilice sólo fuera y lejos de las ventanas, puertas y aberturas.</p> <p>Evitar otros peligros generador, LEER EL MANUAL ANTES DE USAR</p>
	<p style="text-align: center;"><b>⚠ AVERTISSEMENT!</b></p> <p>En utilisant un générateur à l'intérieur PEUT VOUS TUER EN QUELQUES MINUTES.</p> <p>D'air du générateur contient du monoxyde de carbone. C'est un poison qui vous ne pouvez pas voir ou sentir.</p> <p>N'utilisez jamais l'intérieur d'une maison ou garage, même si les portes et fenêtres sont ouvertes.</p> <p>Utilisez uniquement l'extérieur et loin des fenêtres, portes et événements.</p> <p>Éviter d'autres dangers du générateur, LIRE LE MANUEL AVANT UTILISATION</p>

**⚠ DANGER**

In case of an emergency, the owner operator is responsible for proper and safe use of the electric generator system. The manufacturer strongly suggests that the owner operator read the Owner's Manual in its entirety and understand all operating instructions before using the electrical standby generator. If not properly adhered to, damage can occur to the system causing fire, electrical shock and even death. The manufacturer also strongly recommends instructing other users to properly start/stop and operate the unit in time of need.

## Operation and Maintenance

It is the sole responsibility of the owner to periodically service and maintain safe operating conditions. We recommend inspecting the system for all fluid levels, fluid leaks, loose belts, and unusual noises from normal operation. If this is observed, contact your installer, local service provider or email us at [info@solarelios.com](mailto:info@solarelios.com). To ensure your system is always in top condition, contact us for an authorized service center near you for repairs and extended service agreements. This will give you peace of mind that your investment will always be in good condition when an emergency arises.

Standard maintenance service and the replacement of parts are the responsibility of the owner/operator and, as such, are not considered defects in materials or workmanship within the terms of the warranty. Personal operating habits and usage contribute to the need for maintenance and service. Proper maintenance and care of the generator ensures a minimum number of problems and keep operating expenses at a minimum. Talk to your Dealer about maintenance Plans.



Save These Instructions – The manufacturer suggests that these rules for safe operation be copied and posted near the unit's installation site. Safety should be stressed to all operators and potential operators of this equipment.

Study these SAFETY RULES carefully before installing, operating, or servicing this equipment. Become familiar with this Owner's Manual and with the unit. The generator can operate safely, efficiently, and reliably only if it is properly installed, operated, and maintained. Many accidents are caused by failing to follow simple and fundamental rules or precautions.

The manufacturer cannot anticipate every possible circumstance that might involve a hazard. The warnings in this manual, and on tags and decals affixed to the unit are, therefore, not all-inclusive. If using a procedure, work method or operating technique the manufacturer does not specifically recommend, ensure that it is safe for others. Also make sure the procedure, work method or operating technique utilized does not render the generator unsafe.

- Despite the safety design features of this generator, operating this system improperly, and neglecting routine maintenance can cause possible injury or death. Allow only certified and licensed personnel to install, operate, and maintain this system.
- Potentially lethal voltages are generated by these generators. Make sure all steps are taken to render the machine safe before attempting to work or service the generator system.
- Parts of the generator are rotating at high speeds and are hot during operation. Exercise care near operating generators.
- Installation must always comply with applicable local and state codes, standards, laws, and regulations.

## COMMON HAZARDS

- A running generator gives off carbon monoxide, and odorless, colorless poison gas. Breathing in carbon monoxide can cause headaches, fatigue, dizziness, nausea, vomiting, confusion, fainting, seizures or death.
- The engine exhaust fumes contain carbon monoxide, which can be DEADLY. This dangerous gas, if inhaled in sufficient concentrations, can cause unconsciousness or even death. Do NOT alter or add to the exhaust system or do anything that might render the system unsafe or in noncompliance with applicable codes and standards.
- Install a battery-operated carbon monoxide alarm indoors, according to manufacturer's instructions and recommendations.
- Adequate, unobstructed flow of cooling and ventilating air is critical to correct generator operation. Do not alter the installation or permit even partial blockage of ventilation, as this can seriously affect the safe operation of the generator. The generator MUST be installed and operated outdoors only.
- Keep hands, feet, clothing, etc., away from drive belts, fans, and other moving or hot parts. Never remove any drive belt or fan guard while the unit is operating.
- When working on this equipment, always remain alert. Never work on the equipment when physically or mentally fatigued.
- Inspect the generator regularly and contact the nearest Dealer for parts needing repair or replacement.
- Before performing any maintenance on the generator, disconnect battery cables to prevent accidental start up. Disconnect the cable from the battery post indicated by a NEGATIVE, NEG or (–) first, then remove the POSITIVE, POS or (+) cable. When reconnecting the cables, connect the POSITIVE cable first, and the NEGATIVE cable last.
- Never use the generator or any of its parts as a step. Stepping on the unit can stress and break parts, and may result in dangerous operating conditions from leaking exhaust gases, fuel leakage, oil leakage, etc. NEVER STAND ON THE UNIT!

## ELECTRICAL HAZARDS

- Generators covered by this manual produce dangerous electrical voltages and can cause fatal electrical shock. Utility power delivers extremely high and dangerous voltages to the transfer switch, as does the standby generator when it is in operation. Avoid contact with bare wires, terminals, connections, etc., while the unit is running. Ensure all appropriate covers, guards and barriers are in place, secured and/ or locked before operating the generator. If work must be done around an operating unit, stand on an insulated, dry surface to reduce shock hazard. **It is required that a wooden pallet and rubber mat placed on top be used to avoid potential and possible shock.**
- Do not handle any kind of electrical device while standing in water, while barefoot, or while hands or feet are wet. DANGEROUS ELECTRICAL SHOCK MAY RESULT.
- The National Electrical Code (NEC) requires the frame and external electrically conductive parts of the generator to be connected to an approved earth ground. Local electrical codes also may require proper grounding of the generator electrical system. Refer and adhere to all state and local electrical codes.
- After installing this home standby electrical system, the generator may crank and start at any time without warning. When this occurs, load circuits are transferred to the STANDBY (generator) power source. To prevent possible injury if such a start and transfer occur, always set the generator's AUTO/OFF/MANUAL switch to its OFF position before working on equipment and remove the fuse from the generator control panel.
- In case of an accident caused by electric shock, immediately shut down the source of electrical power by pushing the emergency stop switch located on the outside of the unit. Use a non-conducting implement to push the emergency stop switch if possible. If it is not possible, attempt to free the victim from the live conductor. AVOID DIRECT CONTACT WITH THE VICTIM. Use a non-conducting item, such as a dry rope or wooden board, to free the victim from the live conductor.

If the victim is unconscious, apply first aid and get immediate medical attention.

- Never wear jewelry when working on this equipment. Jewelry can conduct electricity resulting in electric shock or may get caught in moving components causing injury.

### **POSSIBLE FIRE HAZARDS!**

- For fire safety, the generator must be installed and maintained properly. Installation must always comply with applicable codes, standards, laws, and regulations. Adhere strictly to local, state and national electrical and building codes. Comply with all regulations the Occupational Safety and Health Administration (OSHA) has established. Also, ensure that the generator is installed in accordance with the manufacturer's instructions and recommendations. Following proper installation, do not alter any installation that might render the unit noncompliance with the beforementioned codes, standards, laws and regulations.
- Always keep a fire extinguisher near the generator. Extinguishers rated "ABC" by the National Fire Protection Association are appropriate for use on the standby electrical system. Keep the extinguisher properly charged and be familiar with its use. Consult the local fire department with any questions pertaining to fire extinguishers.

### **POSSIBLE EXPLOSION HAZARDS!**

- Do not smoke around the generator. Wipe up any fuel or oil spills immediately. Ensure that no combustible materials are left in the generator compartment, or on or near the generator, as FIRE or EXPLOSION may result. Keep the area surrounding the generator clean and free from debris.
- Gaseous fluids such as natural gas (NG) and liquid propane gas (LPG) are extremely EXPLOSIVE. Install the fuel supply system according to applicable fuel-gas codes. Before placing the standby electric system into service, fuel system lines must be properly purged and leak tested according to applicable code. After installation, inspect the fuel system periodically for leaks. Make sure there are no gas leaks, use a digital gas detector.

**STANDARDS INDEX.** In the absence of pertinent standards, codes, regulations and laws, the published information listed below may be used as an installation guide for this equipment.

- NFPA No. 37, stationary combustion engines and gas turbines, available from the National Fire Protection Association, 470 Atlantic Avenue, Boston, ma 02210.
- NFPA No. 76a, essential electrical systems for health care facilities, available same as item 1.
- NFPA No. 54, national fuel gas code, available same as item 1.
- NFPA No. 58, American national standard for storage and handling of liquefied petroleum gas, available same as item 1.
- NFPA No. 70, NFPA handbook of national electric code, available same as item 1.
- Article X, national building code, available from the American insurance association, 85 John Street, New York, N.Y. 10038.
- AGRICULTURAL WIRING HANDBOOK, available from the Food and Energy Council, 909 University Avenue, Columbia, Mo 65201.
- ASAE EP-3634, installation and maintenance of farm standby electrical systems, available from the American society of agricultural engineers, 2950 miles road, St. Joseph, mi 49085.
- NFPA No. 30, flammable and combustible liquids code, available same as item 1.
- AGRICULTURAL WIRING HANDBOOK, available from the Food and Energy Council, 909 University Avenue, Columbia, Mo 65201.
- ASAE EP-3634, installation and maintenance of farm standby electrical systems, available from the American society of agricultural engineers, 2950 miles road, St. Joseph, mi 49085.
- NFPA No. 30, flammable and combustible liquids code, available same as item 1.



Only qualified electricians or contractors should attempt such installations, which must comply strictly with applicable local and state codes, standards, and regulations.

### Uncrating and Initial Inspection

After uncrating, carefully inspect the contents for any visible damage. Do not tilt the machine more than 30 degrees. Try to avoid transporting on uneven ground. Violent shaking and vibration during transportation may affect the unit.

- This standby generator set is ready for installation with a weather protective enclosure that is intended for outdoor installation use only!
- This ETL listed standby generator set may be packaged with an automatic transfer switch (ATS) optional.
- This ETL listed, 2-pole switch is rated at 200 AC amperes at 250 volts maximum. The 200 Amp transfer switch is rated for indoor or outdoor use. Elios ATS to be used with Elios Generator only.



If this generator is used to power electrical loads normally powered by a utility power source, it is required by code to install a transfer switch. The transfer switch must effectively isolate the electrical system from the utility distribution system when the generator is operating (NEC 700, 701 & 702). Failure to isolate an electrical system by such means will result in damage to the generator and may result in injury or death to utility power workers due to back feed of electrical energy.

If any loss or damage is noted at time of delivery, have the person(s) making the delivery, note all damage on the freight bill or affix their signature under the consignor's memo of loss or damage. If a loss or damage is noted after delivery, separate the damaged materials and contact the carrier for claim procedures.

“Concealed damage” is understood to mean damage to the contents of a package that is not in evidence at the time of delivery but is discovered later.

To properly open the cover, press down on the center top lip and release the latch with key. If pressure is not applied from the top, the roof may appear stuck. Always verify that the lock is released before attempting to lift the roof.

### NEC REQUIREMENTS.

Local code enforcement may require that AFCIs (Arc Fault Circuit Interrupters) be incorporated into the transfer switch distribution panel. The Transfer Switch provided will accept AFCI's.

Siemens P/N. Q115AF - 15A or Q120AF - 20A can be obtained from a local electrical wholesaler and will simply replace any of the single pole circuit breakers supplied in the Transfer Switch distribution panel.

## FIRST STEP

Contact your local building inspector or City Hall to be aware of all federal, state and local codes that could impact the installation. Secure all required permits before starting the project.

Carefully read and follow all procedures and safety precautions detailed in the installation guide. If any portion of the installation manual, technical manual, or other factory-supplied documents is not completely understood, contact your authorized local dealer for assistance.

It is extremely important to comply with all relevant NEC, NFPA and OSHA standards as well as all federal, state and local building and electrical codes.

As with any generator, this unit must be installed in accordance with current NFPA 37 and NFPA 70 standards as well as any other federal, state, and local codes for minimum distances from other structures. As a minimum distance, use 24 inches (60.96cm) from home or building.



### GENERATOR LOCATION AND SITE PREPARATION

1. Place concrete pad as close as possible to both breaker box and fuel supply. **IMPORTANT!** Pre-wired control harness located inside ATS is 20 feet long. Call for longer 25ft, 50ft and 80ft harness. Leave adequate room around the area for service access. You must **CHECK LOCAL CODE** for proper distance between generator and structure! We suggest the clearance between genset, and combustible materials is not less than 12ft away. Check local code and place high enough to keep rising water from reaching the generator. Select an open space that will provide adequate and unobstructed airflow. Electrical interference with such items as cell phones, computers, TV's and other electrical devices and equipment can occur when standing close to or next to a running standby system.

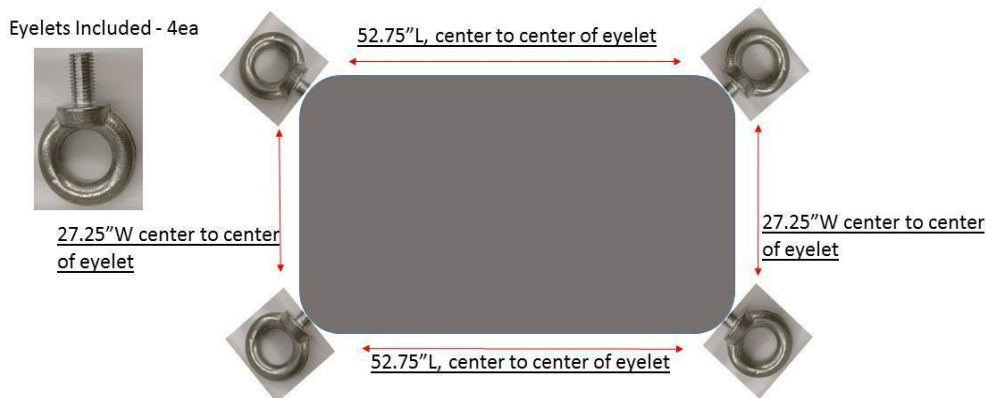

It is recommended that a concrete pad be utilized that is 3 to 4 inches past each eyelet on each side. Pad depth 4".

It is strongly advised that you use provided eyelet bolts for lifting system to a concrete pad, center to center of eyelets, 52.75" L X 27.25" W.

Just Base Cabinet Measurements – 29" W X 52.75" L

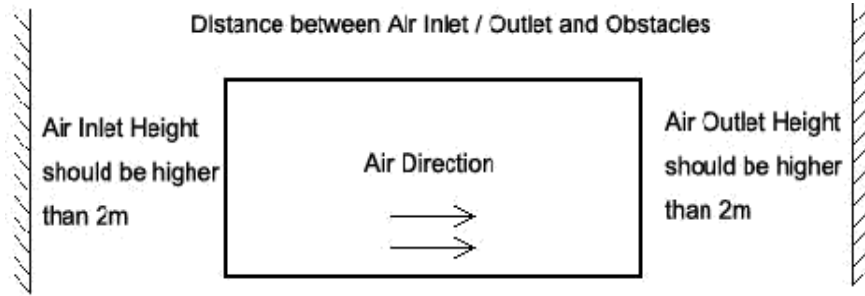

2. Place the unit so air vents won't become clogged with leaves, grass, snow, or debris. Make sure exhaust fumes will not enter the building through eaves, windows, ventilation fans or other air intakes. Build a rectangular form out of 2"X6 wooden studs. Dig an area approximately 4 inches deep and about 4 to 6 inches, longer and wider than the footprint of the generator. Place wooden frame in hole leaving approximately 2" above ground. Place polyurethane film in the bottom and fill with pea gravel or crushed stone along with rebar reinforcement. Level and pack gravel or stone evenly. The concrete pad is now ready to be poured. When pouring concrete, set grade 5 anchor bolts in wet concrete based on the footprint of generator lining up with holes on the base of the unit. Once complete level and finish concrete pad and allow to set for 48 hours.
3. Inspect packaging and generator for exterior shipping damage. Remove all packaging material.
4. Make sure the lifting equipment to be used has sufficient capacity to safely handle the weight of the generator (Elios 20 kW Liquid-Cooled Generator gross weight 850lbs). Use nylon lifting straps and connect them to the lifting eyebolts on each corner of the base frame to avoid damage to the enclosure (lifting eyebolts included) Make sure straps are lifting straight upward and do not pinch lid! Set generator into place and anchor tightly to concrete pad using grade 5 hardware.
5. When using a forklift, you must ensure that the forks are wide enough to lift the unit from the bottom. Fully insert the fork legs completely through the bottom of the machine. Pay attention to the machine components avoiding damage from the bottom, lift and set flat on concrete pad. Avoid tilting and dropping generators. Handle with care.
6. Center the generator onto pad so that there is equal distance between the generator on all four sides, making sure, the generator is level within 1/16" inch.
7. **IMPORTANT!** Connect an approved ground strap to the grounding lug on the base of frame and to an approved earth ground or grounding rod as specified by local codes and regulations.



**DO THIS STEP FIRST BEFORE ANY OTHER INSTALLATION PROCEDURE IS PERFORMED!**

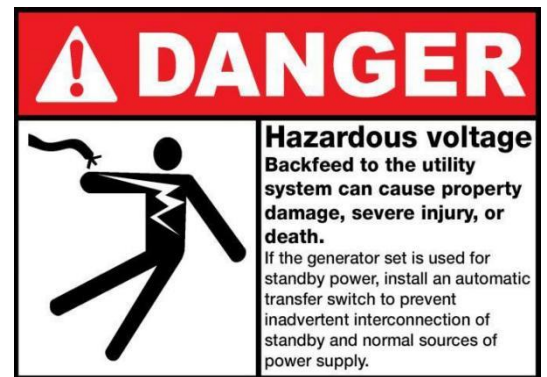

## Engine Prestart and Preparation

All necessary installation and maintenance must be conducted and performed by authorized licensed personnel. Before starting the engine for the first time, engine oil and radiator coolant must be added. An initial fluid inspection and pre-check is recommended before starting a genset for the first time or when a unit has been in operation for over 20 hours. It can also be used as a quick review of all fluids. Check all the following items before running the system for the first time.



**IMPORTANT NOTE! Unit is not shipped with engine oil or coolant from Factory!**

After installing the generator, fill the engine with recommended oil weight based on ambient temperature shown below and add radiator coolant. Prior to initial startup, replace all service panels and close the lid. Start the engine and allow 10 minutes for the system to warm up. After this has been performed, remove service panels rise lid and check for any leaks or drips. If found, tighten lose hoses, clamps or plugs. Recheck all fluid levels and top off as necessary.

Engine Oil. The unit is not shipped with oil from the factory!!! Only use high-quality Synthetic motor detergent oil “Classified with SAE viscosity ratings. Fill with the recommended amount of oil as specified.

Overfilling or under filling can cause damage to the engine. Use the following recommended or similar type of engine oil.

Temperature	Mobil 1 Synthetic Oil or equivalent recommended
Below 32° F (0° C)	SAE 0W-40
32° to 80° F (-1° to 27° C)	SAE 10W-40
Above 80° F (27° C)	SAE 15W-50

- Place funnel in engine oil inlet.
- First time operation will require 4 liters or (4.25qts) of oil
- Check oil gauge dipstick regularly; oil level should be kept between top and bottom lines, always. It is preferred to be at the top mark but not over.



Fuel Oil Level Mark

Engine Oil

## COOLING SYSTEM

Use only Pink OAT coolant in the cooling system. Do not use tap water, or water that contains salt or alkalis! Using non-distilled water creates scale in the radiator, causing corrosion and premature wear.



You must check and maintain all fuel, lubricant, and coolant levels. Not doing so will accelerate and shorten the life of the standby system. Attention must be paid to all fluid systems and annually serviced by an authorized service provider.

### Converting from Natural Gas (NG) to Liquid Propane Gas (LPG)

Most generators are configured for natural gas operation at the factory. Switching over to LP Vapor is a simple procedure.

### Fuel Conversion

These fuels are flammable and explosive materials. Do not operate around open flames.



### When using LPG as fuel:

1. Prior to each operation, you should check various components and handle any loose fasteners. Check if there's any fuel leakage around pipes and connections by utilizing a digital gas leak detector (soapy water can be used). Service for any leakage immediately!
2. When changing fuel supply, close the gas valve supply and allow fuel in the fuel line to burn off. Then turn off the main power breaker on the standby control panel.
3. After fuel supply conversion from LPG to NG replacement, use a gas leak detector for any leakage.
4. Periodically check the pressure reducing valve, if the solenoid valve sealing pad is deformed. You must first close the manual valve on the fuel supply. Then start the engine. Use up the gas in the fuel line before you remove the solenoid valve and other parts, if not, this will have a greater risk of high-pressure or vapor lock and is not safe.
5. The Pressure reducer is an important component of the gas supply system. You should pay particular attention to its operation. If leakage occurs, the unit should be replaced. Periodically remove the pollution discharge plug on the pressure reducer. Drain off the oil and condensation. If the obstruction is not drained off, it can seriously affect its performance.
6. When using NG as fuel:
  - Before each operation, you should check the integrity of the various components and handle any loose fasteners immediately! Check if there's any leakage from the fuel lines, pipes, and connections (soapy water can be used). Take care of leakage ASAP!
  - Periodically check the pressure reducer, and if the solenoid valve sealing pad is deformed, replace it.
  - Periodically check to see if any visible signs of wear, aging or leak detection are observed, repair, or replacement. Soapy water can be used to detect leaks around connections.
  - During maintenance of the gas line, the valve must be closed prior to repair.
  - When the engine is operating, especially at high load, it should run 1-3 min in no load state, to allow the engine to cool. Do not touch hot engine or electrical parts. The engine and exhaust system components become extremely hot during operation. Make sure the unit is disconnected from the main power and main gas lines before converting.

Two fuel connections on the fuel block allow field conversion between natural gas (NG) and Liquid

Propane (LPG). The fuel metering valves are factory-set and sealed to provide the best possible hot and cold start.

- Use the following procedure to convert fuel from one type to another. Natural Gas (NG) and Liquid Propane (LPG) Conversion
- Use a pressure reducing valve to reduce LPG pressure supply. Pushing the button as attached pictures show below to the natural gas or LP vapor per fuel which you want to use. Push in for LPG and out for NG



### Liquid propane (LP Vapor)

In engines set up to run on Liquid propane, please check the fuel supply pressure, lower or higher-pressure range will result in equipment failure. Inlet pressure 1.7kPa to 3.5kPa, and gas line should be no longer than 16 feet or 5 meters, the inner diameter shall not be less than (0.63”) or 16mm.

Pressure Relief Valve

## INSTALLING & CONNECTING GAS LINES

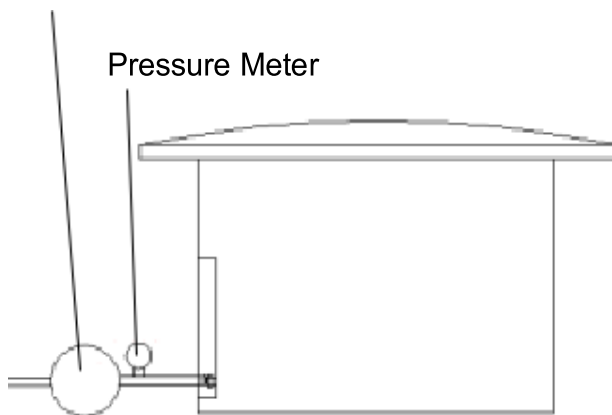

1. Natural gas and LP Vapors are highly explosive substances; you must follow all safety, codes, standards and regulations. Use a certified plumber or licensed contractor familiar with local codes to make all gas line connections. Always use AGA-approved gas pipe and a quality pipe sealant or joint compound. Verify the capacity of the natural gas meter or the LP tank to provide sufficient fuel for both the generator and other operating appliances.

2. Most applications will require an external manual shutoff valve on the fuel line.
3. Only use UL Listed or AGA-approved flexible fuel line in accordance with local regulations, when connecting the gas line to the generator. The section of the flexible fuel line is to ensure that vibration from the generator does not create a gas leak at a connection point. Because of this, it's important for the fuel line to be installed with as few connection points and bends as possible.
4. Do not bend flexible fuel lines to avoid using your elbow. Bending the flexible fuel line decreases its ability to absorb vibrations and defeats the purpose. It also prevents smooth fuel flow.
5. After checking for leaks, check the gas pressure at the REGULATOR to make sure there's enough gas pressure for generator operation. See Owner's Manual for fuel pressure specifications. If not within these limits, contact your local gas supplier.
6. After checking and testing the gas pressure regulator, close the main shutoff valve.



# TRANSFER SWITCH WIRING DIAGRAM

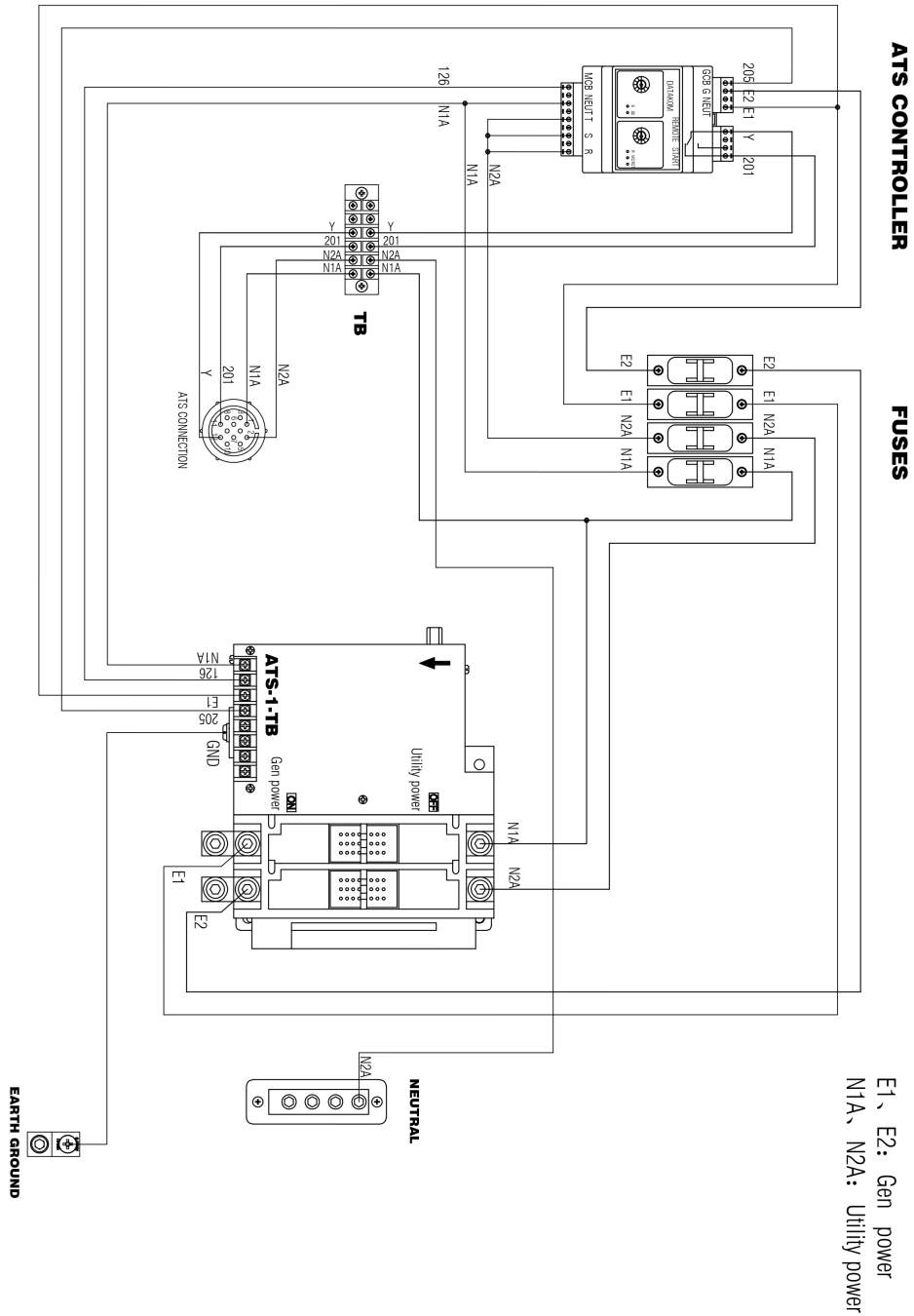

1. Locate area where electrical conduit will enter structure and drill 1.75" hole. Feed conduit through hole, sealing both exterior and interior with caulk.
2. Seal the hole with silicone caulk. Don't forget to caulk the hole inside the house as well.
3. Remove knockout in the back of the connection box, feed wires through the back of the box and secure the conduit with lock nut.
4. Mount connection box over whole structure. Seal around all sides with weatherproof caulk.
5. Connect all wires to the lugs inside the connection box. Connect, black to black, red to red, white to white. Connect ground wire to the ground lug and then connect breaker connections.
6. Close cover and lock connection box.



### Initial battery connection and controller activation

1. When battery power is applied to the generator and the power switch is in the on position, the digital controller will light up. However, the generator controller still needs to be activated and programmed before it will automatically run in the event of a power outage.
2. Battery Connection - connect positive red lead wire first (+) and then negative lead black wire (-) to matching positive (+) and negative (-) terminals on battery. Connect negative (-) leads last!
3. Programming the generator is a one-time process that is guided by the controller's screen prompts. Once the product is activated, the controller screen will not prompt you again, even if you disconnect the generator battery. See SmartGen Owner's Manual for programming
4. An "Activation Password" is required to unlock the controller for basic programming (date/time/delay/ exercise) and to enter full feature parameter settings. Please contact your dealer with your Serial Number to receive activation password and register your liquid cooled system for warranty.
5. **IMPORTANT!** The generator will not start, and circuit board damage can occur if the battery is connected in reverse.

(Before initial use the maintenance free battery should be tested for voltage, if >12.6V, it can be installed and used immediately; After first time use or <12.6V it should be re-charge before use.)

When replacing the battery, always use the same size battery and number type: Group 25 550CCA, Lead-acid.

**CAUTION** – Do not dispose of battery or batteries in a fire. Batteries are capable of exploding.

**CAUTION** – Do not open or mutilate the battery. Released electrolytes have been known to be harmful to skin, eyes and to be toxic.

**CAUTION** – The battery has a risk of electric shock and high short circuit current.

**CAUTION** – A battery presents a risk of electrical shock and high short circuit. The following precautions are to be observed when working on batteries:

1. Remove watches, rings, or other metal objects.
2. Use tools with insulated handles.
3. Wear rubber gloves, an apron, eye protection and boots.
4. Do not lay tools or metal parts on top of batteries.

Make sure the generator set is grounded. Check grounding strap to make sure the generator set ground terminal is securely grounded to a grounding rod.

For first time use, you should operate according to these steps:

(514) 863 7097

www.solarelios.com

info@solarelios.com

- Installing battery - take off red cap on positive battery terminal.
- Use a multi-meter to check voltage of battery before installing and starting. If the reading is below 12.6V, recharge the battery.
- Connect positive terminal lead. Tighten terminal lead nut on battery and place red rubber cover over terminal.
- Follow the same steps for negative or black battery lead, then place rubber cover over terminal.



**The battery represents a risk of high short circuit current. When working on the battery, always remove watches, rings, or other metal objects, and only use tools that have insulated handles!** *Installing, Servicing, or Exchanging the Battery* should be performed or supervised by knowledgeable personnel. Battery connection or exchange requires precautions and protective gear. Always wear face and eye protection with electrical rubber gloves, boots and a battery apron. Keep unauthorized personnel away from battery.

### GENERATOR CONNECTION

If the switch was purchased separately from the generator, a Seal-Tite electrical whip will need to be connected to the generator. To complete the wiring, run 3/4" conduit for the power leads and control wires from the external connection box to the generator.

1. Feed the wires through the back of the generator and secure the conduit with a lock nut.
2. Run power leads through the strain relief hole provided.
3. The circuit breaker and control panel are located under the top lid. Unlock and lift open to gain access.

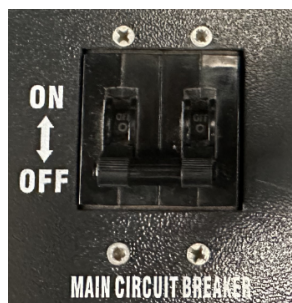

4. Remove the screws on the control panel cover to gain access to the connection area.
5. Feed the wires through the back of the generator and secure the conduit with locking nut.
6. Run power leads through the strain relief provided.

7. The circuit breaker is mounted inside next to the generator digital controller.
8. Secure circuit connections.
9. Users must connect the GND wire to the grounding lug and tighten it.
10. The GND wire should be the same size but not smaller than the load wire.
11. Connect according to the following connector bar from left side to right side.
12. Connect according to the following type due to different Models.

Use insulated and certified wire/cable hose to connect the output hole. And the AC output wires/cable, and ATS control wires shall be separated by an insulation bushing (min 1.0mm). Tighten all wires before operating generator set, or it will cause short circuit failure. Do not connect generator sets together; damage may occur if wires are connected in reverse. The AC output wires shall be at least 3AWG, and temperature rating shall not less than 75°C, and copper wire.

## OPERATION

Icon	Function	Description
	Stop/Reset	Stops the generator when operating in either Auto or Manual mode. If an alarm is active, pressing this button will reset the alarm. In Stop mode, holding the button for 3 seconds will perform an indicator light (lamp) test. If the generator is in the process of stopping, pressing the button again will force an immediate shutdown.
	Start	Starts the generator when in Manual mode. Pressing this button will initiate the generator startup. If pressed again during the startup sequence, the generator will skip to the next step, allowing for a faster start.
	Manual	Pressing this key will set the module into manual mode.
	Auto	Pressing this key will set the module into auto mode.
	C/O	Toggles between the C/O interface and the main display screen. Pressing this button switches the controller view between the C/O (Close/Open) interface and the main page. In Manual mode, use the Up or Down keys within the C/O interface to control the switch (close or open).
	Set/Confirm	Pressing this key will enter Main Menu. In setting parameter status, pressing this key will shift cursor or confirm setting value.
	Up/Increase	Scrolls the screen up. Shift the cursor up or increase the set value in parameter setting menu. In C/O interface under manual mode: pressing this button can control mains close or open (HGM4020 series). Pressing this button can control gen close (HGM4010 series).

	<p>Down/Decrease</p>	<p>Scrolls the screen down. Shift the cursor down or decrease the set value in parameter setting menu. In C/O interface under manual mode: pressing this button can control gen close or open (HGM4020 series). Pressing this button can control gen open (HGM4010 series).</p>
---	----------------------	---

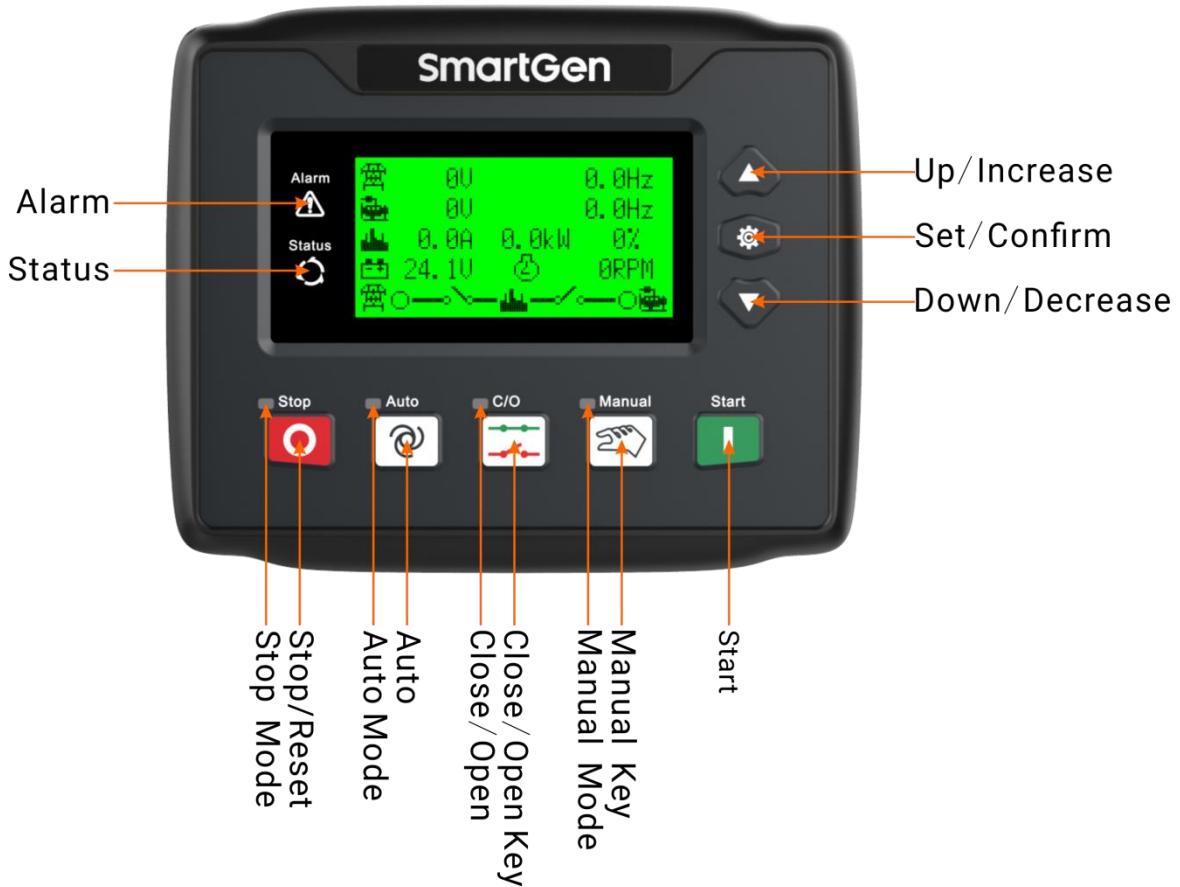

HGM4020CAN Front Panel Indication

**▲ NOTE:** Part of indicator lights illustration:

**Alarm Indicators:** slowly flash when warning alarms; fast flash when shutdown alarms; light is off when no alarms.

**Status Indicators:** Light is off when genset is standby; flash once per second during start up or shut down; always on when normal operation.

## AUTO START/STOP OPERATION

Press , its indicator lights, and controller enters Auto mode.

### Auto Start Sequence

HGM4020: When mains are abnormal (over and under voltage, loss of phase), it enters mains “abnormal delay”, and LCD displays count down time. When mains abnormal delay is over, it enters “start delay”. “Start delay” timer is shown on LCD.

When the start delay is over, preheat relay outputs (if this be configured), “preheat start delay XX s” is shown on LCD.

When preheat delay is over, fuel relay outputs 1s and then starting relay outputs; if engine crank fails during “cranking time”, the fuel relay and starting relay deactivated and it enters “crank rest time” to wait for next crank.

If engine crank fails within setting times, the fifth line of LCD turns black and “fail to start” message appears on fifth line of LCD at the same time.

In case of successful crank attempt, “safety on delay” starts. During this period, low oil pressure, high water temperature, under speed, charging failure alarms and auxiliary inputs (if configured) are disabled. As soon as this delay is over, “start idle delay” is initiated (if configured).

During “start idle delay”, under speed, under frequency, under voltage alarms are inhibited. When this delay is over, “warming up delay” starts (if configured).

When “warming up delay” is over, if generator state is normal, its indicator will be illuminated. If voltage and frequency has reached on-load requirements, the closing relay will be energized, generator will accept load, generator power indicator will turn on, and generator will enter normal running state; if voltage and frequency are abnormal, the controller will initiate shutdown alarm (shutdown alarm will be displayed on LCD alarm page).





### Auto Stop Sequence

HGM4020: When mains return normal during genset running, it enters mains voltage “normal delay”. After mains comes to normal, mains status indicator is illuminated and “stop delay” initiated.

When the stop delay is over, close generator relay is un-energized; the generator enters “cooling down time”. After “transfer rest time”, close mains relay is energized. Mains accept load and generator indicator extinguished while mains indicator lights. Idle relay is energized as soon as entering “stop idle delay” (if configured).



If enter “ETS hold delay”, ETS relay is energized. Fuel relay is deactivated. Then enters gen-set “fail to stop time”, auto decides whether generator stops or not automatically. Enter “generator at rest” as soon as “after stop time” is over. If the genset fails to stop, the controller will initiate alarms (fail to stop warning is shown on LCD).

## MANUAL START/STOP OPERATION

HGM4020: Manual mode is selected by pressing the  button; an LED beside the button will illuminate to confirm the operation; press  button to start the genset, it can automatically judge crank success and accelerate to high-speed running. If high temperature, low oil pressure, over speed and abnormal voltage occur during genset running, the controller can effectively protect it from stopping (detail procedures please refer to No.4~9 of Auto start sequence). Under Manual Mode, load breaker won't transfer automatically, and  key should be pushed to enter the C/O interface. Through  key to control mains switch open/close and  key to control generator switch open/close.

Manual stop: pressing  key can stop the running genset. (detail procedures please refer to No.3~7 of Auto stops sequence).

## EMERGENCY START UP

Simultaneously press  and  in manual mode will force the generator to crank. Successful start will not be judged according to crank disconnect conditions, operator will have to crank the starter motor manually; when operator decides that the unit has fired, he/she should release the button and starting output will be deactivated, safety on delay will be initiated.

## PROTECTION

**Warnings.** When the controller detects the warning signals, it will only send alarms and not stop the genset. Besides, the LCD displays warning information.

**Table 4 Warning Alarms**

No.	Type	Description
	High Temperature	When the controller detects that temperature has exceeded the pre-set value while shutdown is prohibited or detects that the Aux. input high temperature while shutdown is prohibited, it will initiate a warning alarm, and the corresponding alarm information will be displayed on LCD.
	Low Oil Pressure	When the controller detects that the oil pressure has fallen below the pre-set value while shutdown is prohibited or detects that the Aux. input low oil pressure while shutdown is prohibited, it will initiate a warning alarm, and the corresponding alarm information will be displayed on LCD.
	Gen Over Current	When the controller detects that the genset current has exceeded the pre-set value and the over current delay has expired, it will initiate a warning alarm, and the corresponding alarm information will be displayed on LCD.
	Fail to Stop	After "fail to stop" delay/ETS delay has expired, if genset does not stop completely, it will initiate a warning alarm, and the corresponding alarm information will be displayed on LCD.
	Low Fuel Level	When the controller detects that the fuel level has fallen below the pre-set value while shutdown is prohibited or detects that the Aux. input low fuel level while shutdown is prohibited, it will initiate a warning alarm, and the corresponding alarm information will be displayed on LCD.
	Charge Alt Failure	When the controller detects that charger voltage has fallen below the battery voltage and the difference value exceeds pre-set charging voltage difference value, it will initiate a warning alarm, and the corresponding alarm information will be displayed on LCD.
	Battery Under Volt	When the controller detects that battery voltage has fallen below the pre-set value, it will initiate a warning alarm, and the corresponding alarm information will be displayed on LCD.
	Battery Over Volt	When the controller detects that battery voltage has exceeded the pre-set value, it will initiate a warning alarm, and the corresponding alarm information will be displayed on LCD.
	Auxiliary Input	When the controller detects that the auxiliary input warning signals, it will initiate a warning alarm, and the corresponding alarm information will be displayed on LCD.
	Loss of Speed Signal	When the controller detects that the engine speed is 0 and the delay is

		0, it will initiate a warning alarm, and the corresponding alarm information will be displayed on LCD.
	Low Coolant Level	When the controller detects the low coolant level, input is active, it will initiate a warning alarm, and the corresponding alarm information will be displayed on LCD.
	Temp. Sensor Open	When the controller detects that the temperature sensor is an open circuit and the action selects "Warn", it will initiate a warning alarm, and the corresponding alarm information will be displayed on LCD.
	Oil Pressure Sensor Open	When the controller detects that the oil pressure sensor is open circuit and the action selects "Warn", it will initiate a warning alarm, and the corresponding alarm information will be displayed on LCD.
	Fuel Level Sensor Open	When the controller detects that the level sensor is an open circuit and the action selects "Warn", it will initiate a warning alarm, and the corresponding alarm information will be displayed on LCD.
	Temp. Sensor 2 Open	If the config. sensor set as temperature sensor, when the controller detects that the temperature sensor is an open circuit and the action selects "Warn", it will initiate a warning alarm, and the corresponding alarm information will be displayed on LCD.
	Oil Pressure Sensor 2 Open	If the config. sensor set as oil pressure sensor, when the controller detects that the oil pressure sensor is an open circuit and the action selects "Warn", it will initiate a warning alarm, and the corresponding alarm information will be displayed on LCD.
	Coolant Level Sensor Open	If the config. sensor set as level sensor, when the controller detects that the level sensor is an open circuit and the action selects "Warn", it will initiate a warning alarm, and the corresponding alarm information will be displayed on LCD.
	High Temperature 2	When the controller detects that config. Sensor (sensor type: temperature sensor) has exceeded the pre-set value while shutdown is prohibited, it will initiate a warning alarm, and the corresponding alarm information will be displayed on LCD.
	Low Oil Pressure 2	When the controller detects that config. sensor (sensor type: oil pressure sensor) has fallen below the pre-set value while shutdown is prohibited, it will initiate a warning alarm, and the corresponding alarm information will be displayed on LCD.
	Low Coolant Level	When the controller detects that config. sensor (sensor type: level sensor) has fallen below the pre-set value while shutdown is prohibited, it will initiate a warning alarm, and the corresponding alarm information will be displayed on LCD.
	Maintenance Due	When genset running time has exceeded the user setting maintenance time and the action selects "Warn", it will initiate a warning alarm, and the corresponding alarm information will be displayed on LCD. The maintenance alarm will reset if the action selects "Inactive".
	Gen Over Volt.	When the controller detects that the voltage is higher than the set value, it will send warning signals, and the corresponding alarm information will be displayed on LCD.
	Gen Under Volt.	When the controller detects that the voltage is lower than the set value, it will send warning signals, and the corresponding alarm information will be displayed on LCD.

	Gen Over Freq.	When the controller detects that the frequency is higher than the set value, it will send warning signals, and the corresponding alarm information will be displayed on LCD.
	Gen Under Freq.	When the controller detects that the frequency is lower than the set value, it will send warning signals, and the corresponding alarm information will be displayed on LCD.
	Charge Alt Failure	When the controller detects the charger, alt failure warn input is active, it will send alarm signals, and the corresponding alarm information will be displayed on LCD.
	Overpower	When the controller detects that the power value (power is positive) is higher than the set value and the action select warn, it will send warning signals, and the corresponding alarm information will be displayed on LCD.
	ECU Warn	When the controller gets the warning signals from the engine via J1939, it will send warning signals, and the corresponding alarm information will be displayed on LCD.

## SHUTDOWN ALARM

When the controller detects shutdown alarm, it will send signals to stop the generator, and the corresponding alarm information will be displayed on LCD.

**Table 5 Shutdown Alarms**

No.	Type	Description
1	Emergency Stop	When the controller detects emergency stop signals, it will send stop signals, and the corresponding alarm information will be displayed on LCD.
2	Over Speed	When the controller detects that the speed value is higher than the set value, it will send stop signals, and the corresponding alarm information will be displayed on LCD.
3	Under Speed	When the controller detects that the speed value is lower than the set value, it will send stop signals, and the corresponding alarm information will be displayed on LCD.
4	Loss of Speed Signal	When controller detects speed value equals 0, and delay value isn't 0 (action selects "Shutdown"), it will send stop signals, and the corresponding alarm information will be displayed on LCD.
5	Gen Over Frequency	When the controller detects that the frequency value is higher than the set value, it will send stop signals, and the corresponding alarm information will be displayed on LCD.
6	Gen Under Frequency	When the controller detects that the frequency value is lower than the set value, it will send stop signals, and the corresponding alarm information will be displayed on LCD.
7	Gen Over Voltage	When the controller detects that the voltage value is higher than the set value, it will send stop signals, and the corresponding alarm information will be displayed on LCD.
8	Gen Under Voltage	When the controller detects that the voltage value is lower than the set value, it will send stop signals, and the corresponding alarm information will be displayed on LCD.
9	Gen Over Current	When the controller detects the current value is higher than the set value and the delay value is not 0, it will send stop signals, and the corresponding alarm information will be displayed on LCD.
10	Fail to Start	If genset starts failure within setting start times, controller will send stop signals, and the corresponding alarm information will be displayed on LCD.
11	High Temp.	When the controller detects that the temperature of water/cylinder is higher than the set value, it will send stop signals, and the corresponding alarm information will be displayed on LCD.
12	Low Oil Pressure	When the controller detects that oil pressure is lower than the set value, it will send stop signals, and the corresponding alarm information will be displayed on LCD.
13	No Generate Electricity	When the controller detects that the frequency of genset is 0, it will send stop signals, and the corresponding alarm information will be displayed on LCD.

No.	Type	Description
14	Low Fuel Level	When the controller detects that the fuel level value is lower than the pre-set value or that the low fuel level input is active, the controller sends stop signals, and the corresponding alarm information will be displayed on LCD.
15	Low Coolant Level	When the controller detects that the low coolant level input is active, the controller sends stop signals, and the corresponding alarm information will be displayed on LCD.
16	Temp. Sensor Open	When the controller detects that the sensor, which is connected to the temperature sensor, is an open circuit, and the action selects "Shutdown", it will send stop signals, and the corresponding alarm information will be displayed on LCD.
17	Oil Pressure Sensor Open	When the controller detects that the sensor, which is connected to the oil pressure sensor, is an open circuit, and the action selects "Shutdown", it will send stop signals, and the corresponding alarm information will be displayed on LCD.
18	Fuel Level Sensor Open	When the controller detects that the sensor, which is connected to the fuel level sensor, is an open circuit, and the action selects "Shutdown", it will send stop signals, and the corresponding alarm information will be displayed on LCD.
19	Temp. Sensor 2 Open	When the controller detects that the temp. sensor, which is connected to the programmable sensor, is an open circuit, and the action selects "Shutdown", it will send stop signals, and the corresponding alarm information will be displayed on LCD.
20	Pressure Sensor 2 Open	When the controller detects that the pressure sensor, which is connected to programmable sensor, is an open circuit, and the action selects "Shutdown", it will send stop signals, and the corresponding alarm information will be displayed on LCD.
21	Coolant Level Sensor Open	When the controller detects that the liquid level sensor, which is connected to the programmable sensor, is an open circuit, and the action selects "Shutdown", it will send stop signals, and the corresponding alarm information will be displayed on LCD.
22	High Temp. 2	When the controller detects that the sample value, which adopted by the programmable temperature sensor, is higher than the pre-set value, it will send stop signals, and the corresponding alarm information will be displayed on LCD.
23	Low Pressure 2	When the controller detects that the sample value, which adopted by the programmable pressure sensor, is lower than the pre-set value, it will send stop signals, and the corresponding alarm information will be displayed on LCD.
24	Low Coolant Level	When the controller detects that the sample value, which adopted by the programmable liquid level sensor is lower than the pre-set value, it will send stop signals, and the corresponding alarm information will be displayed on LCD.
25	Maintenance Due	When genset operation time exceeds maintenance time that user pre-set and the action selects "Shutdown", it will send stop signals, and the corresponding alarm information will be displayed on LCD.

No.	Type	Description
26	Overpower	When the controller detects that the power value (power is positive) is higher than the max. set value and the action selects "Shutdown", it will send stop signals, and the corresponding alarm information will be displayed on LCD.
27	Digital Input Port	When the controller detects external active shutdown alarm signals, it will send stop signals, and the corresponding alarm information will be displayed on LCD.
28	ECU Alarm	After the engine starts, the controller does not receive data signals, via J1939, controller sends stop signals.
29	ECU Comm. Failure	When the controller detects that the sensor value is higher than the max. set value, it will send stop signals.

**▲ NOTE:** ECU warns and shutdown alarms illustration, if there are detailed alarms display, controller will check engine based on the content. Otherwise, please look up the engine manual to get the information based on the SPN code.

1. Now connect the red and black power leads to the circuit breaker. Since this is a single-phase application, it does not matter which wire is connected to which lug.
2. Connect the green equipment ground wire to the ground bus bar and torque to 35-inch lbs. The torque values are: • 10-14 AWG = 35 in/lbs. • 8 AWG = 40 in/lbs. • 4-6 AWG = 45 in/lbs.
3. Connect the white neutral wire to the neutral bus bar and torque to 35-inch lbs. The torque values are: • 10-14 AWG = 35 in/lbs. • 8 AWG = 40 in/lbs. • 4-6 AWG = 45 in/lbs.
4. **IMPORTANT NOTE:** Connect the control wires to the correct terminals. To maintain separation of circuits, the DC control wires must be separated from the AC control wires. Wrap insulation over the AC wires OR the DC wires, but not both, from the wire landing area to the outside of the generator. Use cable locks to keep the insulation in place. An improperly connected control wire can damage the generator's control board.

### PARAMETER SETTINGS

Make sure power is on before starting the controller, then press  to enter the parameters setting menu, see fig 1 below:

1. Set Parameters
2. Information
3. Language
4. Time and date

Fig. 1

### Parameters Setting

When entering password interface, input correct password (default: 0318) can set all of the parameter items in Form 1. If there is a need to set more parameters (e.g. Voltage Calibration), please contact the factory.

**▲ CAUTION:** Please change the controller parameters when the generator is in standby mode only (e.g. Crank disconnect conditions selection, auxiliary input, auxiliary output, various delay), otherwise, shutdown and other abnormal conditions may happen.

**▲ CAUTION:** Over voltage set value must be higher than under voltage set value, otherwise over voltage and under voltage condition may occur simultaneously.

**CAUTION:** Over speed set value must be higher than under speed set value, otherwise over speed and under speed condition may occur simultaneously.

**CAUTION:** Please set the generator frequency value as low as possible when cranking, to make the starter separate quickly as soon as possible.

**CAUTION:** Auxiliary input 1~5 could not be set as same items; otherwise, there are abnormal functions. However, the auxiliary output 1~4 can be set as the same items.

**CAUTION:** If you need to shut down after cooling, please set any digital input as "WTH STOP by cool", then connect this input port to ground soundly.

**Information**

LCD will display software version, issue date of the controller.

Note: In this interface, pressing will display the auxiliary inputs and outputs status.

**Language**

Chinese, English, Spanish and Russian interface can be selected.

**Time and Date**

The time and date information can be set in this interface.

Pressing the key at any time will quit the setting and return to the previous settings menu.

## TYPICAL APPLICATION

Typical Application Diagram

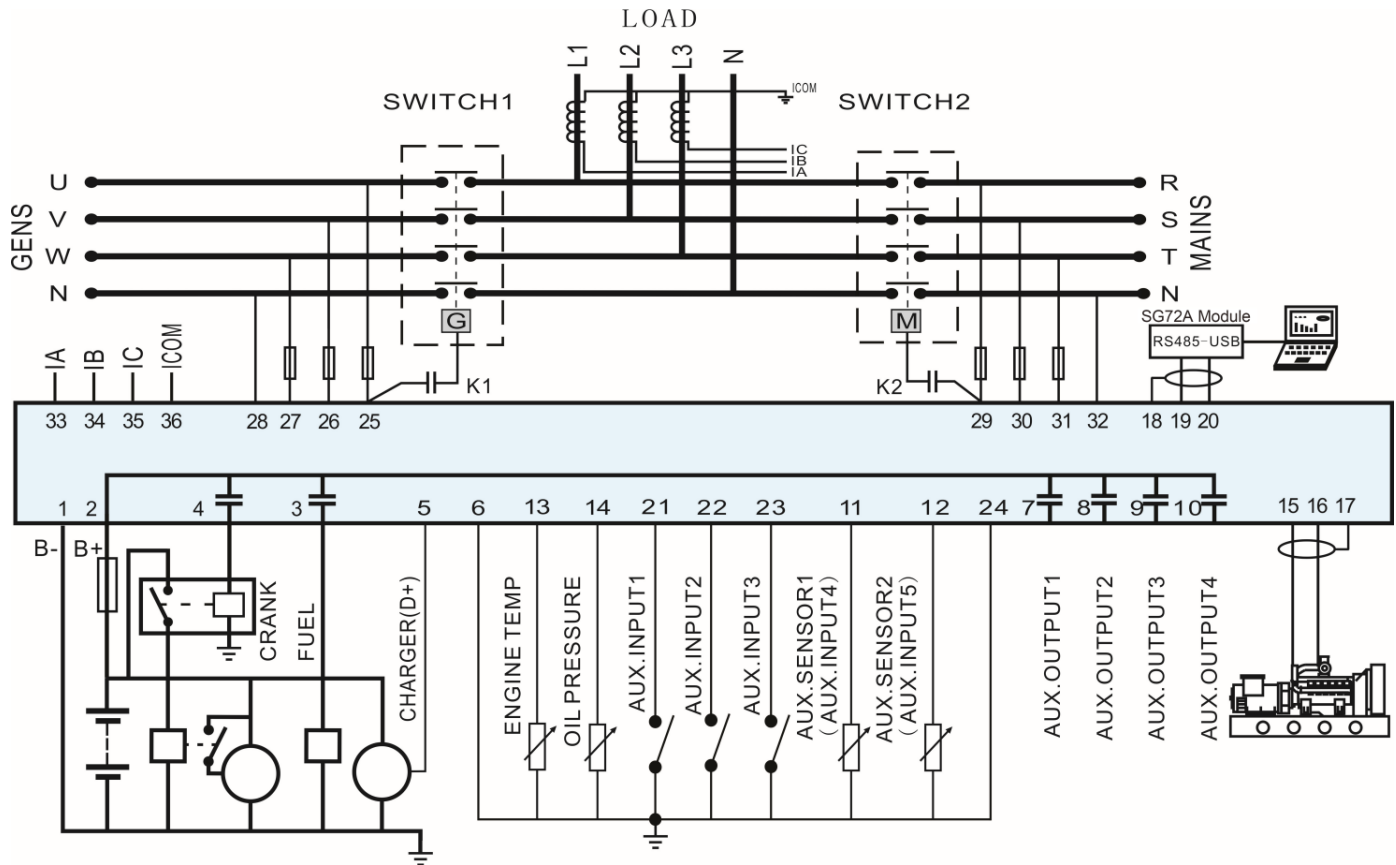

HGM4020NC Typical Application

## WIRING CONNECTION

HGM4020 controller back panel is as follows:

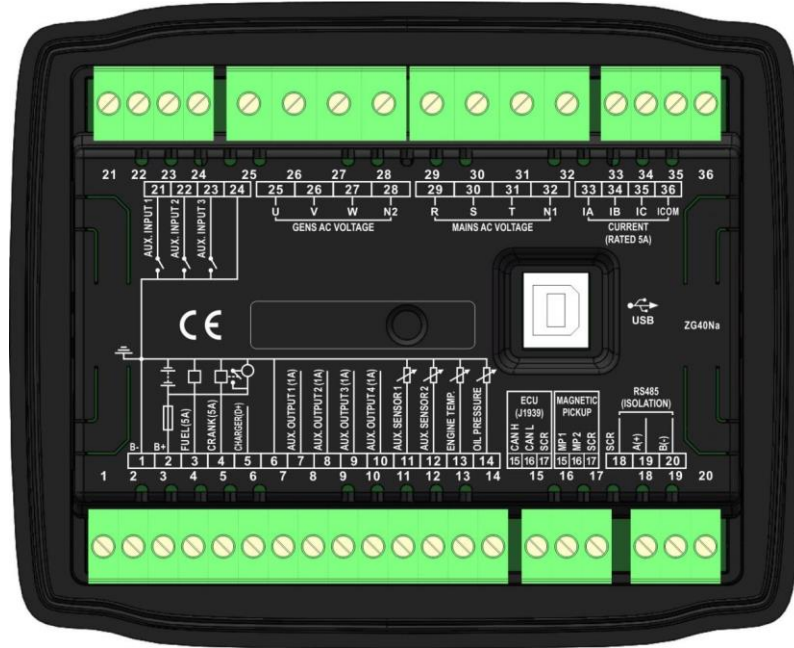

Fig.3 HGM4020 Back Panel

**Table 6 Terminal Wiring Connection**

No.	Function	Cable Size	Remarks	
1	B-	2.5mm <sup>2</sup>	Connected with a negative starter battery.	
2	B+	2.5mm <sup>2</sup>	Connected with a positive starter battery. If the wire length is over 30m, it is better to double wires in parallel. Max. 20A fuse is recommended.	
3	Fuel relay output	1.5mm <sup>2</sup>	B+ is supplied by 2 terminals, rated 5A. Parameter set as “programmable relay output 5”.	
4	Crank relay output	1.5mm <sup>2</sup>	B+ is supplied by 2 terminals, rated 5A.	
5	Charger(D+)	1.0mm <sup>2</sup>	Connected with charger starter’s D+ (WL) terminals. Being hung up If there is not this terminal.	
6	Common earth ground	1.5 mm <sup>2</sup>	Inside connect to B-.	
7	Aux. output 1	1.0mm <sup>2</sup>	B+ is supplied by 2 terminals, rated 1A.	Details see Table 8
8	Aux. output 2	1.0mm <sup>2</sup>	B+ is supplied by 2 terminals, rated 1A.	
9	Aux. output 3	1.0mm <sup>2</sup>	B+ is supplied by 2 terminals, rated 1A.	
10	Aux. output 4	1.0 mm <sup>2</sup>	B+ is supplied by 2 terminals, rated 1A.	
11	Aux. input 1	1.0mm <sup>2</sup>	Used as a liquid level sensor or digital input port 4.	
12	Aux. input 2	1.0mm <sup>2</sup>	Used as programmable sensor or digital input port 5.	
13	Temperature sensor	1.0mm <sup>2</sup>	Connected with water temperature or cylinder temperature resistor	Details see Table 10.

No.	Function	Cable Size	Remarks
			type sensor.
14	Oil pressure sensor	1.0mm <sup>2</sup>	Connected with oil pressure resistor type sensor.
15	CAN H	Speed sensor input	Controller connected with CAN BUS (if with CAN BUS function); Controller connected with speed sensor (if no CAN BUS function); Shielding lines are recommended.
16	CAN L	Speed sensor input; Controller inside connected with battery cathode	
17	CAN common ground		0.5mm <sup>2</sup>
18	RS485 common ground		/
19	RS485A (+)		Impedance-120Ω shielding wire is recommended; its single-end earthed.
20	RS485B (-)		
21	Aux. input 1		Ground connected is active (B-)
22	Aux. input 2		Ground connected is active (B-)
23	Aux. input 3		Ground connected is active (B-)
24	Input COM		Inside connected to B-.
25	Genset U-phase voltage monitoring input		Connected to U-phase output of genset (2A fuse recommended).
26	Genset V-phase voltage monitoring input		Connected to V-phase output of the genset (2A fuse recommended).
27	Genset W-phase voltage monitoring input		Connected to W-phase output of the genset (2A fuse recommended).
28	Genset line N2 input		Connected to the N-line output of the genset.
29	Mains R-phase voltage monitoring input		Connected to R-phase of mains (2A fuse recommended). (HGM4010 without).
30	Mains S-phase voltage monitoring input		Connected to S-phase of mains (2A fuse recommended). (HGM4010 without).
31	Mains T-phase voltage monitoring input		Connected to T-phase of mains (2A fuse recommended). (HGM4010 without).
32	Mains line N1 Input		Connected to line N of mains (HGM4010 without).
33	CT A-phase monitoring input		Outside connected to secondary coil of CT (5A rated).
34	CT B-phase monitoring input		Outside connected to secondary coil of CT (5A rated).
35	CT C-phase monitoring input		Outside connected to secondary coil of CT (5A rated).
36	CT COM		Reference to Installation Instruction.

**▲ NOTE: USB ports in controller rear panel are programmable parameter ports; user can directly configure controller via PC.**

### Automatic Transfer Switch (ATS) Installation

- Before beginning any installation, make sure power is shut OFF to the main distribution panel and carefully read the ATS Owner's Manual that came with the system.
- All wiring must be the correct size and type, and must conform to all codes, standards and regulations. Refer to the Transfer Switch Owner's Manual and the National Electrical Code for additional information.
- The distribution load center switch in the ATS must be mounted close enough to the main distribution panel to accommodate electrical conduit and the included 12 ft. EZ connection wiring harness from ATS to standby unit.
- Make sure no water or corrosive substances can drip onto the transfer switch enclosure.
- Additional wiring harnesses lengths (20, 50 and 80 feet) are available from your dealer.

- Always inspect the switch for shipping damage.
- Never install a transfer switch that shows any signs of damage.
- Protect against impact and mount the switch vertically to a rigid support structure. Make sure the switch is level and plumb.
- The automatic transfer switch is an open transition switch. Open transition switches prevent electrical feedback between the generator and the utility by only allowing load circuits to be connected to one power supply at a time.



- When three-conductor wiring is used, two 120-volt circuits will often share the same neutral wire. To avoid overloading the neutral, either move BOTH circuits that share the neutral or don't move either of them.
- When moving two circuits with a shared neutral, they should be connected to adjacent positions (one above the other) in the transfer switch. That will ensure that the two hot wires are in separate phases and will maintain their relationship to a neutral state.
- Choose a circuit to be backed up and remove the power lead from the breaker.
- Using UL Listed wire nuts, reconnect the power leading to a matching breaker in the transfer switch.
- Make sure each circuit moved is protected by the same size breaker in the transfer switch. 15 Amp circuits must be connected to 15 Amp breakers and 20 Amp circuits to 20 Amp breakers.
- Connect large neutral to the neutral bar in the distribution panel.
- Install a 2-pole breaker in the distribution panel to protect the transfer switch. The required amp rating of the breaker depends on which transfer switch is used. The ATS included with this unit is 200 Amps. This breaker must be compatible with the existing electrical distribution panel.
- Install the breaker in two adjacent empty slots (one above the other) in the main panel.
- EZ connects wiring harness, from ATS to generator control panel. Locate control panel wiring harness prewired inside ATS. The 12-foot-long controller harness passes through the electrical access ports on the corner of the generator above the gas line connection.
- EZ Pre-Wired Controller harness w/female plug is located inside the ATS.

**Generator Electrical Access Port Easy Controller receptacle on Generator**

Controller wiring harness inside ATS with Easy Connect

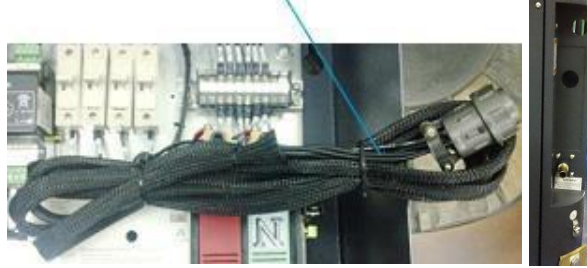

**Wires/cables hose**

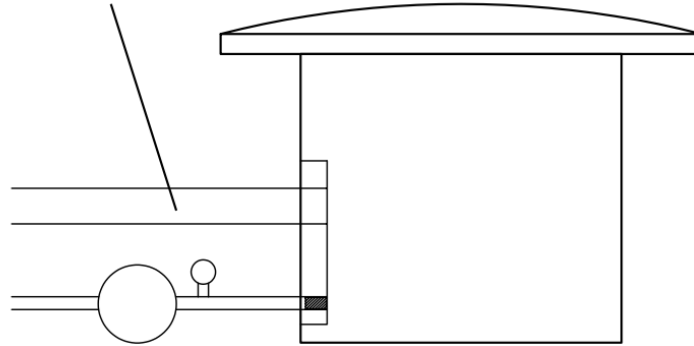

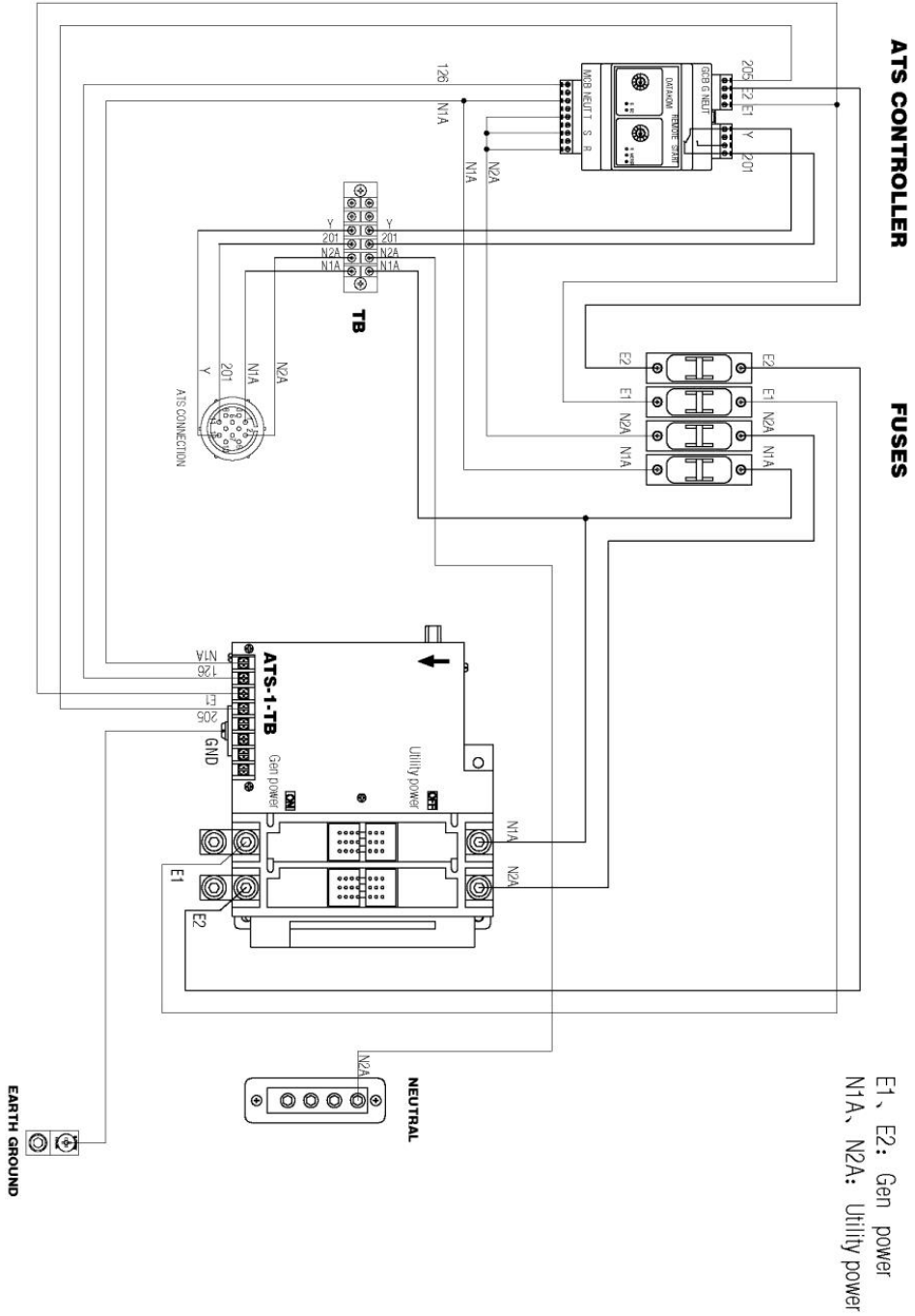

- The connection receptacle is located on the back side of the control panel inside the standby generator. Remove rear panel to view the connection, from ATS. The wire will go out through the wire outlet on the enclosure, passing harness through wire access in standby.
- When all priority circuits have been moved to the transfer switch, close the main breaker to restore utility power and make sure utility voltage at the transfer switch is correct. Refer to NFPA 70-E for safety equipment required when working inside a live transfer switch.

TYPICAL ATS WIRING DIAGRAM



## TESTING

1. Switch the generator's main circuit breaker, located on the control panel in the OFF position, and put the ATS switch in the OFF position.
2. Make sure utility power is OFF and place all the priority circuit breakers in the transfer switch in the OFF position as well.
3. Locate the transfer of power switch inside the ATS. Use included handle to move the main contacts to the standby power, or generator position.
4. NEVER OPERATE THE TRANSFER SWITCH MANUALLY WHEN LOADS ARE CONNECTED!
5. Start the engine by turning the fuel and power switches ON position. Allow fuel to flow for 15 to 20 seconds. Test and smell of gas leaks. Press  "MAN" button first then press start button .
6. Allow the engine to warm up and then switch the generator's main breaker to the ON position. The generator is now supplying electricity to the transfer switch but is not carrying any load.
7. Be sure that the voltage and frequency of the generator are correct. If line-to-line voltage is not approximately 120/240 volts, refer to the Owner's Manual for the proper adjustments needed.
8. On all models, if line-to-neutral voltage is not 120 volts, check the neutral connection between the generator and transfer switch.
9. When finished checking voltage, switch the generator's main circuit breaker OFF and push the OFF button  to shut down the generator.
10. Make sure the 2-pole circuit breaker installed in the main distribution panel is in the OFF position.
11. Use the transfer handle to move the main contacts in the transfer switch to (utility position). Switch the 2-pole breaker ON in the distribution panel.
12. Now switch the generator's main breaker ON and put the mode switch on AUTO.
13. Shut OFF utility power and make sure the generator starts automatically.
14. If everything works correctly, switch the main breaker to ON position and make sure that power is automatically transferred back to the utility and standby power shuts down automatically.
15. After the engine has completed its cool down cycle and shut down, shut OFF utility power again.
16. When the generator is supplying power to the transfer switch, move the breakers in the switch to the ON position, one at a time, until the generator has accepted the entire selected load.  
**IMPORTANT**
17. With the generator carrying the entire priority load, recheck gas pressure to verify that it is at the same level it was before the generator was started.
18. Even if the generator is running smoothly at this point, a drop-in gas pressure indicates that the supply is barely adequate to supply the generator's needs. Changes in the generator's load, or additional gas demand by other appliances, may affect the generator's overall performance. Verify gas pressure and pipe size.
19. Switch the main breaker ON to restore utility power.
20. The generator will continue to run to allow the engine to cool down before shutting down.
21. Close the main breaker to restore utility power and allow the engine to cool itself down and shut off automatically.
22. Operational tests are now complete. Refer to – Setting the Automatic Exercise Function to complete the installation.
23. Testing is now complete.
24. Refer to SmartGen Controller Manual: Setting Automatic Exercise Function to complete installation.

## Testing

### CIRCUIT COVERAGE FOR WHOLE HOUSE AND SMALL COMMERCIAL

If the generator is backing up all electrical loads within the panel, the amperage rating of the transfer switch must be equal to or greater than the amperage rating of the normal utility service. Unless a service rated transfer switch is used; a main service disconnect must be located before the transfer switch. The transfer switch must be installed between the utility service entrance and the building's distribution panel.

A service rated transfer switch is installed between the service and the main distribution panel. The service rated switch becomes the main service, so no service disconnect is needed. The existing main distribution panel becomes a sub-panel.

The grounding that is normally in the main panel must be accomplished in the service rated switch and must be disconnected in the existing distribution panel. Refer to the National Electrical Code (NEC) for complete information on grounding and bonding.

### SPECIFIED ELECTRICAL CIRCUIT COVERAGE IMPORTANT

If the generator only powers designated breakers and circuits that are already grouped together and wired into a separate specified distribution panel, the ATS must be installed between the main electrical panel and specified distribution panel. The amperage rating of the transfer switch must be equal to or greater than the highest amperage rating of the utility, and generator breakers feeding the switch.

### ELECTRICAL CONNECTIONS

Secure circuit connections:

- Users must connect the GND wire to the grounding lug and tighten it.
  - The GND wire should be the same gauge as the load wire.
  - Connect according to the following connector bar from left side to right side.
  - Connect according to the following type due to different Models.
  - Use the insulated and certified wire/cable hose to connect the output hose and the AC output wires/cable, and ATS control wires shall be separated by an insulation bushing (min 1.0mm) Tighten all wires before operating generator set, or it will cause short circuit failure, do not connect generator sets together, damage may occur if wires are connected in reverse.
  - The AC output wires shall be at least 3AWG, and temperature rating not less than 75°, and copper wires.
- a. Connect the power leads from both the generator and the utility to the appropriate lugs in the transfer switch. The lugs are clearly marked in the switch.

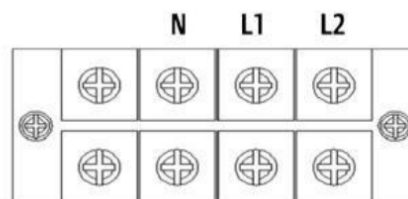

- b. Neutral wires from both the utility and the generator are connected to the same neutral bar in the switch.

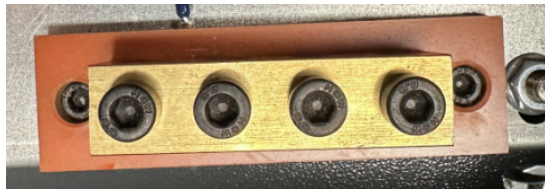

ATS Grounding Bar Lug.



Generator Grounding Bar Lug.

- c. Connect the control wires from the generator to the designated locations.
- d. Complete the transfer switch wiring by connecting the equipment ground wires from both the utility and the generator to the grounding bar lug.
- e. Being careful to support the lugs, torque lugs to 20 Nm. inside the transfer switch.

## FUNCTIONAL TESTING OF UNIT

1. Switch the main utility breaker OFF. Refer to NFPA 70-E for the safety equipment required when working inside a live transfer switch.
2. Engage the utility power and check line-to-line and line-to-neutral voltage at terminals on the transfer contactor. If line-to-line voltage is not approximately 240 volts, disengage utility power and check terminal between the utility and Neutral 1 and Neutral 2. If the line to neutral is not reading approx. 120 volts, shut down utility power and re-inspect neutral terminal connections.
3. Repeat the same voltage checks on terminals to make sure current is flowing properly through the contactor.
4. Switch the generator's main circuit breaker OFF and put the mode switch in the OFF position.
5. Make sure utility power is in the OFF position and place all individual circuits in the main power panel in the OFF position as well.

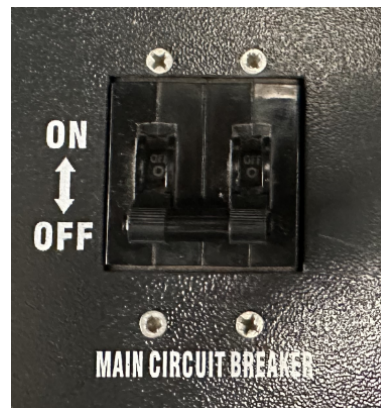

6. Locate the transfer handle; insert the metal end into the slot in the main contactor assembly. Pull the handle DOWN to move the main contacts to the standby power (generator) position. NEVER OPERATE THE TRANSFER SWITCH MANUALLY WHEN LOADS ARE CONNECTED.

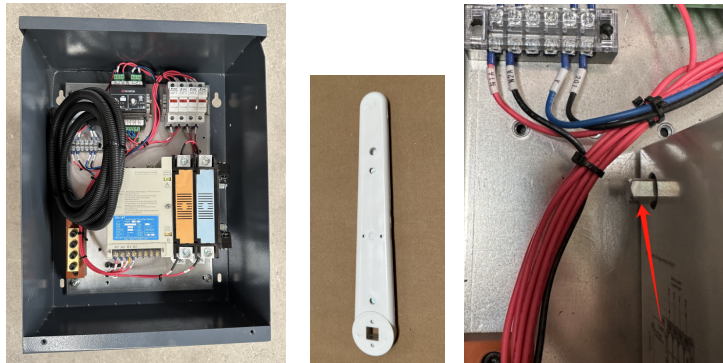

ATS      Transfer Handle      Transfer Lung

7. Locate the transfer handle; insert the metal end into the slot in the main contactor assembly. Pull the handle DOWN to move the main contacts to the standby power (generator) position. NEVER OPERATE THE TRANSFER SWITCH MANUALLY WHEN LOADS ARE CONNECTED.
8. Place generator in MANUAL mode before initiating start. After warmup, transfer the generators main breaker to the ON position. At this point, the system is now supplying electrical power to the ATS but is not applying any electrical load.
9. Check to be sure that voltage and frequency from the generator are correct. If voltage to the line is not at least 240 volts, reference PD20REG-DB Owner's Manual for proper corrective procedures. If the line-to-neutral voltage is not approximately 120 volts, check the neutral connection between the ATS and generator.
10. Transfer the generator's main circuit breaker to the OFF position and put the mode switch in the OFF position to shut down the generator.
11. With utility power still OFF, use the switch handle to move the main contacts to the Utility power ON position.
12. Transfer the main breaker to turn utility power ON.
13. Transfer generator's main breaker to ON position and set the ATS switch in AUTO mode.
14. To test, SHUT OFF utility power. The generator should start automatically after the time set delay has expired.
15. Switch the utility breaker to ON and make sure that power is automatically transferred back to the utility, shutting down generator automatically after cooling down period.
16. Turn OFF utility power once again to automatically start the generator. When power has transferred to the generator, in the distribution panel, turn each of the breakers to ON position one at a time until the generator accepts the full load.
17. With generator on full load, check and recheck gas pressure to verify that it's maintaining the same pressure level, prior to starting generator.
18. CAUTION! Even though the generator sounds and runs smoothly, changes in the electrical loads or additional gas demand by other appliances will affect the generator's performance. Verify gas pressure and pipe sizing. Turn off the gas, unhook the manometer, and reinstall port plug.
19. Transfer utility breaker to ON position to restore electrical utility power.
20. The generator will continue to run to allow the engine to cool down, then it will shut down automatically.
21. Shut OFF utility power again. The generator should start, and the entire electrical load will be transferred to the generator.
22. Close the main breaker to restore utility power and allow the engine to cool down and shut itself off.
23. Operational tests are now complete. Refer to SmartGen Owner's Manual for setting up the Automatic Exercise Functions. This will complete the installation.

### Maintenance of Genset

Regular maintenance is an integral part of the genset. To maintain good reliable condition, please maintain according to specifications.

The following genset maintenance specifications are based on a good working environment and normal operating conditions. Please strictly adhere to the following requirements. If working conditions are less than favorable, (such as excessive dust, humidity, excess ambient temperature or the temperature is too low, etc.) the maintenance period should be shortened accordingly.

### Break-in of New Engine

The life of the engine is greatly dependent on the first 30 hours of use. It is vital to change the engine oil after this initial period. It is also an excellent time to inspect leaks, loose belts, fluid levels, gas lines, and connections. Tighten if necessary.

### Replacing engine oil

Start the engine for several minutes to increase the temperature of the engine oil and then stop the engine.

- Remove front Generator panel
- Place oil pans out in front of the generator.
- Lower Oil Drain hose and loosen oil drain plug using 10mm Allen wrench.
- Inspect oil drain screw and gasket for damaged. Replace it if necessary.
- Tighten oil drain screw and gasket. Inspect for oil leakage!
- Fill with new engine oil and run the engine for 2min. Shut down and recheck the oil level.
- Add if needed. The oil level should be between level A (low) and B (full).



## OIL FILTER REPLACEMENT

The oil filter must be replaced when the engine is cool. The replacement cycle should be according to the maintenance cycle. Steps for replacement:

Use the included oil filter spanner/wrench to remove old oil filter.

- Coat the oil filter gasket surface with a thin layer of oil to seat the new oil filter.
- Tighten the new oil filter.
- Manually run the genset for 3 minutes then shut it down. Check to see if there are any oil leaks. Then check the oil level of the oil pan and fill oil at the specified oil level.
- Use oil filter spanner to fix the oil filter, the torque is between 15N.M-20N.M. When you remove the filter cartridge, the oil level will drop. Be sure to check for oil spills

Direction A: Tighten  
Direction B: Loosen

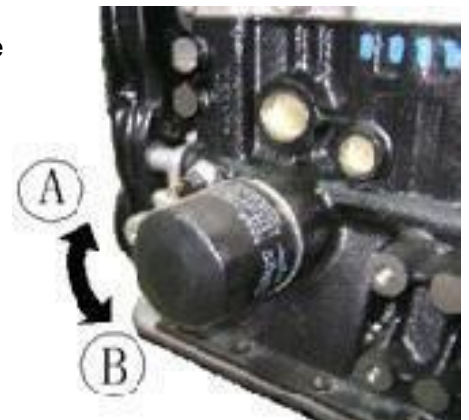

## COOLING SYSTEM MAINTENANCE

When the engine is in operation, there must be enough coolant in the radiator system to allow for proper circulation. It is important to check this level regularly! Only use high-quality antifreeze. See Owner's Manual for more info and approved coolants.



Do not replace cooling liquid when the engine is hot!

Check coolant effectiveness by using coolant tester during annual inspection of system. If needed, change the coolant.

## CHANGING COOLANT

- Remove front cover panel.
- Locate pre-plumbed coolant line with drain plug. Open drain plug with included 10mm Alan wrench and allow coolant to drain.
- Close drain plug securely.
- Refill with approved Pink OAT coolant ONLY.
- Start genset without load for 1 minute. Allow air pockets to dissipate. Stop generator.
- Add cooling liquid to the radiator full level.
- Fill the expansion tank with coolant to the "FULL" level.
- Install the radiator cap and expansion tank cover. Inspect thoroughly for leaks!



**Hard water, saline water, or mineral water is harmful to the engine.  
Use ONLY Pink OAT coolant.**

## WATER PUMP BELT ADJUSTMENT & REPLACEMENT

The Water pump belt is used to cool the engine. If the tension is too loose or too tight, it will cause engine overheating. If you hear the belt slipping or squealing, you should check the following. Adjust or replace.

Belt deflection test:

7~10mm (0.28-0.35in/100N {10.01kgf (22.1 lbs.)})

Adjust deflected belt:

- Stop the engine.
- Use the thumb to press on the belt of the pulley wheel.
- If the tightness is not correct, adjust it by relaxing the regulating wheel, until it is to an acceptable degree.
- Replace the water pump belt when it's cracked, missing sections of the belt, or broken.

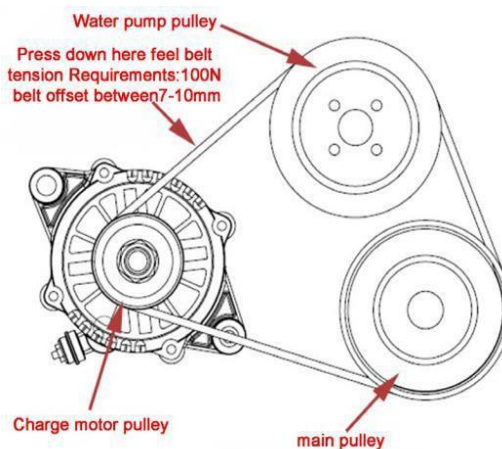

## AIR FILTER MAINTENANCE

Take out the air filter cartridge and clean it based on the maintenance table (on page 43). The steps are as follows:

- Remove air filter cover, take out air filter element.
- **IMPORTANT.** Blow air from the inside of the element toward the outside.
- Clean the filter element using an air filter cleaner, dry with compressed air. **IMPORTANT!** Do not clean with water.
- Replace cracked or damaged air filter elements as soon as possible.
- Reinstall air filter cartridge and air filter cover. Secure clamps.

Open here

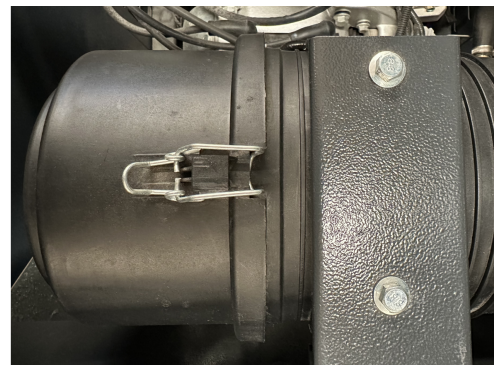

## RADIATOR MAINTENANCE

**Check radiator hose often. Inspect hose clamps for tightness and leakage. If hose clamps are loose, tighten as necessary.**

- If the radiator hose is bulging or cracking, replace the hose immediately!
- Periodically clean the cooling fins of the radiator, using compressed air.

**IMPORTANT!** Lift lid and blow air from the inside out! Do not force air through the radiator from the outside in!

### Winter maintenance

**When temperatures are under 0°C/32°F, please maintain the engine according to the following specifications.**

1. Use winter weight engine oil
2. Check coolant level
3. Use an antifreeze tester to check the effectiveness of the coolant. Add coolant if necessary.
4. For severe cold weather climates, we recommend a cold weather kit (sold separately).

### Ignition System Maintenance

This engine is equipped with an electronic ignition; the order is 1-3-4-2. Suggested spark plug: F6RTC (Autolite 4252) or similar type, Using the wrong type of spark plug will damage the engine.

Replacing spark plugs:

- Remove ignition wires from the spark plug.
- Using a spark plug socket, remove each spark plug from cylinder head.
- Annually inspect spark plugs, replace if visible cracking or carbon buildup is seen on insulators.
- Measure the gap between each new spark plug!

### NOTE

**Correct spark plug gap is 0.9-1.1mm**

- Insert new spark plugs by hand first, then tighten with spark plug socket
- Reinstall ignition wires to correct cylinders.

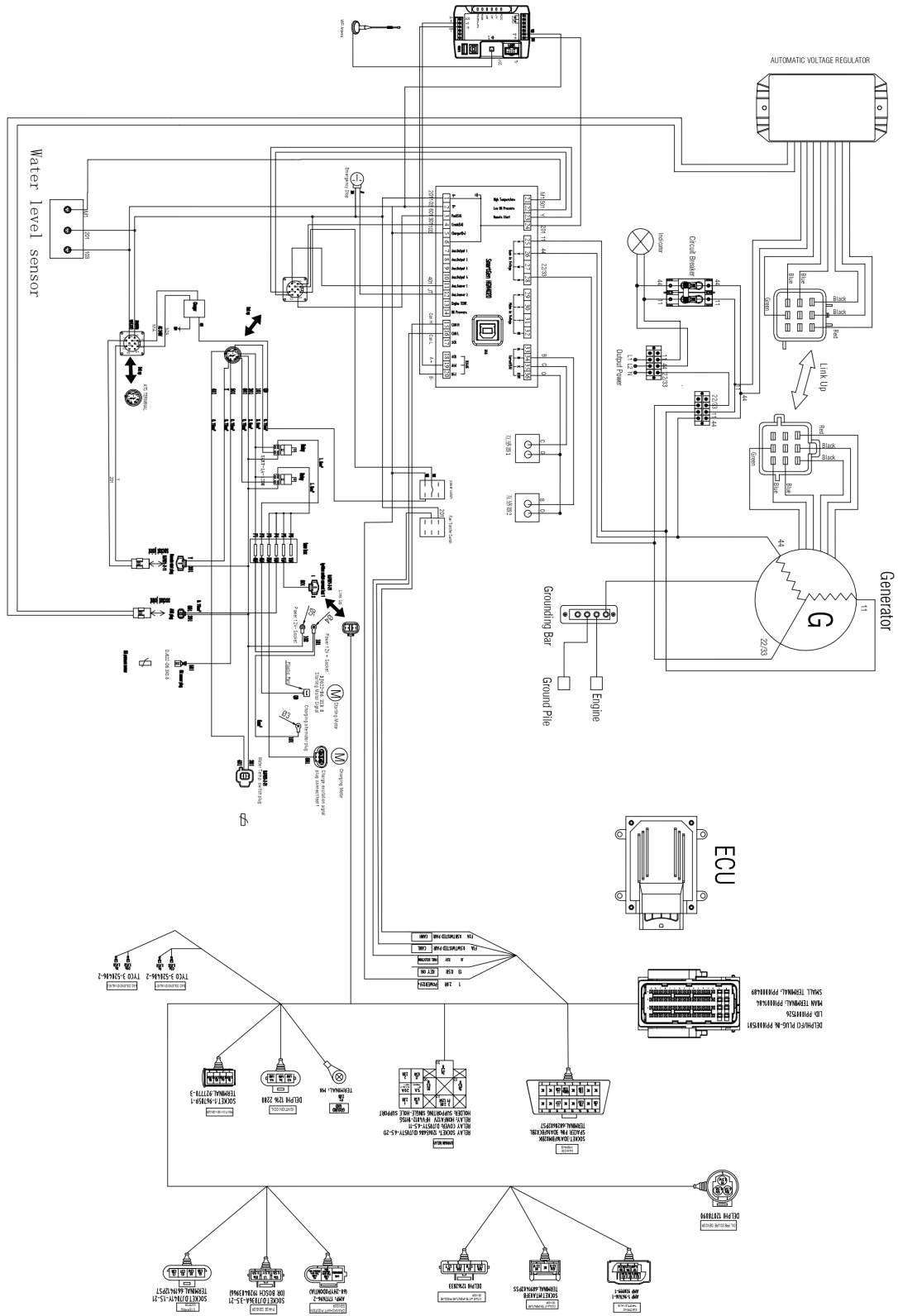

## ENGINE MAINTENANCE

Utilize the following table to maintain the engine system. This will ensure many years of dependable service. This symbol “○” indicates when a maintenance item needs to be performed.

Items	Remarks	1 <sup>st</sup> Use Check First 30 Hours Or Every Year	Every 50 Hours Or Every Year	Every 100 Hours Or Every Year	Every 200 Hours Or Every 2 Years	Every 400 Hours Or Every 4 Years
Oil	Check Oil Level	○	○			
	Replace	○		○		
Oil Filter	Replace	○		○		
Air Filter	Clean		○			
	Replace Filter Element				○	
Spark Plug	Check			○		
	Replace				○	
Cooling System	Check coolant level and leakage occurs	○	○	○	○	○
	Clean radiator				○	
	Check the fan running condition		○			
	Check radiator hose connection		○			
	Change the coolant				○	
Gas Valve	Check/adjust	○			○	
Gas Line	Check the gas line for damage		○			○
Exhaust System	Check to see if there is leakage, tighten or replace if needed		○			
Screws and Nuts	Check all screws & nuts tighten if loose.	○		○		
Water Pump Belt	Adjust tension		○	○		
	Replace				○	
Aging Wires	Check all wires for aging situation and if the connectors are loose or not			○		
Timing Belt	Depends on the wear pattern	Change Every 1000 Hours				
Battery	Check battery voltage while cranking	Change if voltage drop too low when cranking or every 3 years preventive				

### Additional system maintenance

- Keep the generator clean.
- Add lubrication oil and antirust at the frictional position
- Check all the screws loosen or not, and tighten them

### Common Faults and Repair Methods of Generator

Number	FaultSymptoms	Reason & Troubleshooting
1	Generator without power indication	<ol style="list-style-type: none"> <li>1. Check whether battery is damaged</li> <li>2. Fuse broken</li> </ol>
2	Generatorhas power indication but no power output	<ol style="list-style-type: none"> <li>1. Breaker not open</li> <li>2. AC output is poorly connected (check)</li> <li>3. Check AVR and its fuse</li> <li>4. Check carbon brush</li> </ol>
3	Generator overheating	<ol style="list-style-type: none"> <li>1. Lack of coolant or pipe blocked (Add coolant or clean up radiator hoses)</li> <li>2. Thermostat closed or damaged</li> <li>3. Water pump worn out or damaged (Clean or replace pump)</li> <li>4. Too much engine oil (Remove the unnecessary engine oil)</li> <li>5. Damage of rotor bearing (Replace bearing)</li> <li>6. Radiator blocked or damaged (Clean or replace radiator)</li> <li>7. Short circuit of stator winding (Check wiring)</li> <li>8. Rubbing of stator and rotor (Check, adjust gap)</li> </ol>
4	Insufficient power output	<ol style="list-style-type: none"> <li>1. Engine throttle worn out</li> <li>2. Air filter blocked</li> <li>3. Some spark or cylinder wire is damaged</li> <li>4. Too much oil</li> <li>5. Piston ring worn out</li> </ol>

### Common Faults and Repair Methods of Engine

Symptoms	Possible Solutions
Controller has no response with power	Check starting batteries Check controller connection wirings Check DCC fuse
Generator shuts down	Check the water/cylinder temperature is too high or not Check the genset AC voltage, check DC fuse
Low oil pressure alarm after crank disconnect	Check oil level, then oil pressure sensor and its connections
High coolant temp alarm after crank disconnect	Check coolant level, then temperature sensor and its connections.
Shutdown Alarm	Check related switch and its connections according to the information on LCD, check auxiliary input ports
Fail to start	Check fuel oil circuit and its connections Check starting batteries Check speed sensor and its connections, refer to engine manual
Starter no response	Check starter connections, check starting batteries
Stepping Motor Reverse	Cross connect the S11 and S12 Cross connect the S21 and S22 Change configuration (motor reduce direction) via PC
GOV is out of control.	Check the speed sensor voltage is no less than 2V when cranking Check the connections of S11, S12, S21, and S22

### Common Faults and Repair Methods of Engine

Number	Fault	Check
1	Hard to start	<p><b>Electrical system fault</b></p> <ol style="list-style-type: none"> <li>1. Low battery with not enough power.</li> <li>2. Check battery for loose terminals.</li> <li>3. Starting fault.</li> <li>4. Ignition system fault.</li> <li>5. Spark plug carbon deposit and tarnish.</li> <li>6. Improper gap of spark plugs.</li> <li>7. Spark plug insulation burns out or electrode short circuit.</li> <li>8. Burned out Ignition coil.</li> <li>9. Solenoid valve damage.</li> </ol> <p><b>Handling method</b></p> <ol style="list-style-type: none"> <li>1. Check all ignition wires to spark plugs, make sure all are secure.</li> <li>2. Test spark. Remove ignition wire, using insulated glove hold wire next to plug to see if sparks are present.</li> <li>3. Check the voltage of battery, if under 12.4 volts DC; Recharge.</li> <li>4. Replace or clean spark plugs.</li> <li>5. Replace ignition coil, high pressure wire, solenoid valve.</li> </ol>
		<p><b>Gas supply system fault</b></p> <ol style="list-style-type: none"> <li>1. Check main gas on/off valve (open valve).</li> <li>2. Pressure reducer or solenoid valve damaged (replace).</li> <li>3. Supply voltage is too low, cannot open the pipe solenoid and solenoid of the pressure reducer.</li> </ol> <p><b>Dealing method for Item 3: replace or charge battery</b></p> <ol style="list-style-type: none"> <li>4. Solenoid valve will not connect (settle).</li> <li>5. Check fuel switch on generator; switch to correct gas (LPG/NG).</li> <li>6. High pressure in the fuel line. Handling method: Use the spanner to open the joint softly. If it leaks, the existing parts are undamaged. Use this method to check each one.</li> <li>7. Low pressure pipe buckling (settle).</li> <li>8. Oil filter is too dirty (clean).</li> <li>9. Check LPG/NG pressure</li> </ol>

## Common Faults and Repair Methods of Engine

Number	Fault	Check
2	Idling unstable	<ol style="list-style-type: none"> <li>1. Pressure reducer seals did not seat well (reseal)</li> <li>2. Check the tightening screw of the mixer to see whether it is loose or not, check all the connections between the gas inlet pipe and mixer for leaks</li> <li>3. Check fixed bolt on speed motor to see whether it is loose or not</li> <li>4. Check the LPG/NG pressure to see whether it is normal or not</li> <li>5. Check the screw of pressure regulating valve to see whether it is loose or not</li> <li>6. Check the LPG tank surface to see whether it has frozen over</li> </ol>
3	Engine will not operate standby	<ol style="list-style-type: none"> <li>1. The top dead center signal of cylinder one is not correct.</li> <li>2. The speed signal is not correct. Elimination method: check or replace the sensor.</li> <li>3. The temperature of the pressure reducing valve is too low.</li> <li>4. Pressure reducer does not work normally; repair or replace.</li> <li>5. Cylinder blow-by: Elimination method: check the cylinder cap of the screw. When necessary, replace the cylinder cap seal.</li> </ol>
4	Engine not providing enough power, or consumption of fuel increases	<ol style="list-style-type: none"> <li>1. Low pressure pipe buckled or too long (settle).</li> <li>2. Ignition system with not enough ignition power.</li> <li>3. Ignition wires and FBT are not connected correctly.</li> <li>4. Ignition wires and spark plugs are not connected properly.</li> <li>5. Some of the cylinders miss ignition. <b>Handling method of 3, 4, 5</b> <ol style="list-style-type: none"> <li>1. Pull out the spark plug, observe pole top to see whether it has burned trace, if there is, then replace the spark plug</li> <li>2. Use multimeter test the resistance of the ignition wires, if damaged, change ignition wires</li> </ol> </li> <li>6. Under pressure of the cylinder (check and adjust valve or replace the piston ring).</li> <li>7. High pressure fuel line blocked or out of shape (clear or replace line).</li> <li>8. Clean or replace the air filter.</li> <li>9. The mixer is not sealed well (replace).</li> <li>10. The joint part of mixer and throttle leaking (settle).</li> <li>11. Check the gas pressure flow.</li> <li>12. Check whether gas is up to standard, use only high-grade LPG.</li> <li>13. Air filter, exhaust system jam, (clean air filter and exhaust pipe).</li> <li>14. Voltage output instability (adjust or change).</li> </ol>

### Common Faults and Repair Methods of Engine

Number	Fault	Check
5	SuddenStop	<ol style="list-style-type: none"> <li>1. Safety fuse burned out (replace)</li> <li>2. Loss of GND connection (settle)</li> <li>3. Pressure reducer water cycle emerges ice block (handling method: clear the water cycle)</li> <li>4. Pressure reducer low-pressure chamber leaks or diaphragm broken, repair or replace (settle or replace)</li> <li>5. Air filter is too dirty – check or clean</li> <li>6. Solenoid valve fault closed</li> <li>7. Fault of emergency stop switch</li> </ol>
6	Abnormal sound when the engine is operating	<ol style="list-style-type: none"> <li>1. Ignition timing is early and causes detonation; check distributor timing!</li> <li>2. Ignition timing is late which causes backfiring of exhaust. Dealing methods for Item 1 and 2: adjust the ignition timing on the distributor.</li> <li>3. Tolerance between piston and cylinder is incorrect, it knocks when starting engine, noise dissipates after warming up of engine.</li> <li>4. The gap between piston pin and pin hole is too big, the sound is light but clearer during idling.</li> <li>5. The gap between main bearing and connecting rod bearing is worn, can be heard especially at lower speed, it sounds heavy and strong.</li> <li>6. Lose crankshaft bearing, can hear noise when idling.</li> <li>7. Broken Valve Spring, excessive valve clearance, that can be heard knocking around the cylinder cap. Dealing methods for Item 3, 4, 5, 6 and 7: replace the parts, ensure proper tolerance and gaps.</li> <li>8. When the piston hits the cylinder head, you can hear the knocking of metal around the cylinder head. Repair method: check the piston and valve to see if damage has occurred.</li> </ol>
7	Temperature of the engine oil is too high	<ol style="list-style-type: none"> <li>1. Check around the engine compartment for leaks.</li> <li>2. Too much engine load; Reduce load.</li> <li>3. Too much or not enough engine oil.</li> <li>4. Down exhaust is too much. Dealing methods for Item 4: replace the piston ring or the cylinder sleeve.</li> <li>5. Blockage in the oil cooler, oil temperature controller valve opened, and the temperature is too high. Radiator intake vent is blocked by dirt and debris.</li> <li>6. Oil marks are not correct (oil viscosity is too high).</li> </ol>

## Common Faults and Repair Methods of Engine

Number	Fault	Check
8	Pressure of engine oil is low	<ol style="list-style-type: none"> <li>1. Not enough oil in the oil pan. Dealing method: add oil to the selected level.</li> <li>2. Damage of oil pump gear. Dealing method: replace the oil pump.</li> <li>3. Blockage in the oil strainer or the oil filter.</li> <li>4. Damage or blocking in the relief valve or the pressure stabilize spring.</li> <li>5. Blockage or leakage in the oil line. Dealing methods for Item 3, 4 and 5: replace parts.</li> </ol>
9	Temperature of engine coolant is too high	<ol style="list-style-type: none"> <li>1. Water thermostat is stuck, method; check and replace thermostat.</li> <li>2. Coolant: test and replace if necessary.</li> <li>3. If the engine load is too much, reduce it.</li> <li>4. Check for proper ventilation around the radiator air intake vent.</li> </ol>
10	Starterfault	<ol style="list-style-type: none"> <li>1. Starter will not engage.</li> <li>2. Weak starter engagement.</li> <li>3. Starter disengagement is slow or delayed.</li> </ol>
11	Muffler withblack smoke	<ol style="list-style-type: none"> <li>1. Check the air filter for blockage or obstructions.</li> <li>2. Pressure regulating valve does not work normally. Prevention method: adjust the screw on the valve.</li> <li>3. Ignition timing too early, adjust ignition timing.</li> <li>4. The spark plug does not function normally.</li> <li>5. Ignition wires do not function normally.</li> <li>6. High pressure fuel lines do not work normally. Project 4,5 and 6 handling method: replace the related accessories.</li> </ol>
12	Muffler withblue smoke	<ol style="list-style-type: none"> <li>1. Check engine oil level, if too much, drain excess oil.</li> <li>2. Replace the piston ring.</li> <li>3. Overhaul or replace piston and ring.</li> </ol>
13	Muffler withwhite	<ol style="list-style-type: none"> <li>1. Engine preheating.</li> <li>2. Water in the cylinder, check head gasket, and overhaul the engine cylinder if needed.</li> </ol>
14	Muffler withflare up and backfire	<ol style="list-style-type: none"> <li>1. Carburetor floater oil level is too high, adjust the floater.</li> <li>2. Exhaust valve is not totally sealing, polish the valve.</li> <li>3. Ignition timing too late, adjust the ignition timing.</li> </ol>
15	Load speed, drops too much	<ol style="list-style-type: none"> <li>1. Clogged fuel line (check and clean fuel line).</li> <li>2. Dirty air filter (clean the air filter).</li> <li>3. Improper valve clearance (repair and adjust).</li> </ol>

### ENGINE, PRIMARY PARTS AND STRUCTURE

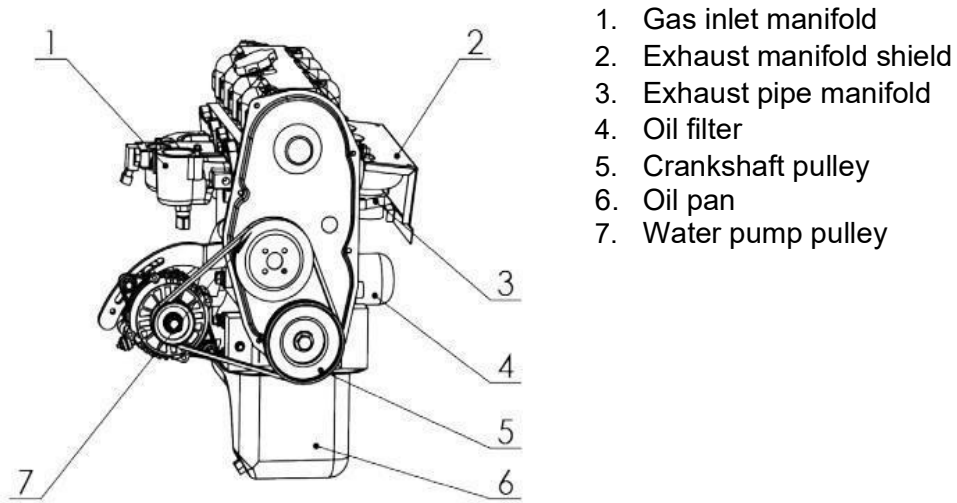

1. Gas inlet manifold
2. Exhaust manifold shield
3. Exhaust pipe manifold
4. Oil filter
5. Crankshaft pulley
6. Oil pan
7. Water pump pulley

### Engine Specifications

LIMITED WARRANTY	5 YEARS
ENGINE PART #	465QR
VOLUME (cc)	998
COMPRESSION RATIO	9.5:1
IGNITION SYSTEM	ECM
ELECTRIC START	YES
ENGINE ALTERNATOR	QDY112 12V 0.8KW
FUEL TYPE	NG/LPG
CYLINDER BORE & STROKE (mm × mm)	L4-65.5×74
ASPIRATION TYPE	NATURAL ASPIRATION
OIL CAPACITY	4.0L
SPIN ON OIL FILTER	YES
CYLINDER BLOCK	CAST IRON
SLEEVE	CAST IRON
CHARGING	14V/70A CHARGING MOTOR
STARTING CURRENT (CCA)	550
COOLING SYSTEM	LIQUID COOLED
OVERHEAT STOP	YES
LOW OIL PRESSURE STOP	YES

## Generator Alternator

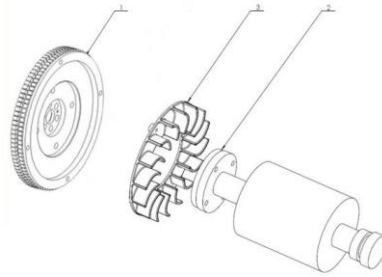

1. Fly Wheel
2. Alternator rotor
3. Alternator fan

This generator is directly coupled and attached to the engine.

### Generator Alternator Specifications

ALTERNATOR TYPE	Synchronous, rotating, magnetic field
VOLT. REG. SYSTEM	AVR
EXCITATION TYPE	BRUSH
POLES	2
THD @ FULL LOAD	≤5%
INSULATION CLASS	F
STATOR WINDING MATERIAL	COPPER
ROTOR WINDING MATERIAL	COPPER
ROTOR OD (mm)	164
STATOR OUTSIDE DIAMETER (mm)	270
STACK LENGTH (mm)	200
LAMINATION MATERIAL	cold rolling
CONNECTION METHOD	DIRECT COUPLED
Motor bearings	

The generator unit is assembled from many integrated components, including the primary silent cooling system, electronic speed control system, automatic power generating system, multi-energy power generation technologies, intelligent control systems, and ultra-low temperature starting technology.

RATED POWER (KW)	LPG	20
	NG	18
FREQUENCY (HZ)		60
FREQUENCY (HZ)		60
SPEED (RPM)		3600
RATED VOLT (V)		120/240
RATED CURRENT (A)	LPG	83.3
	NG	75
PHASE		Single-phase
POWER FACTOR		1.0
PROTECTION LEVEL		IP23
INSULATION		F
POLE		2

## Generator Components and Enclosure

The main frame and chassis are the primary structures to which all other component pieces are attached. The structure makes up the main noise protection and reduction features of the generator set. Other component parts include the chassis, Radiator compartments, electronic control box compartments, and electronic screen board compartments.

*Inner Components*

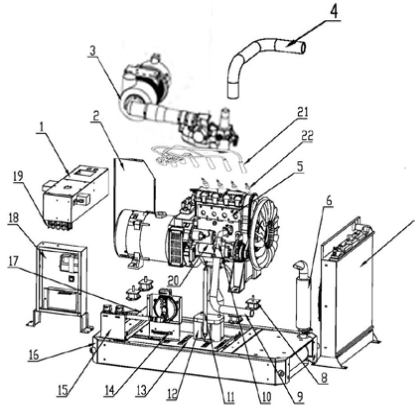

1		Electric control system	1
2		Electric control box support	1
3		Gas inlet system	1
4		Radiator part	1
5		Exhaust part	1
6		Shock absorption	4
7		Winding battery	1
8		Battery base	1
9		GND	1
10		Unit base	1
11		Gas part	1
12		Motor beams	1
13		Distribution box	1
14		Engine alternator	1

### Enclosure Parts for Elios 20 kW Liquid-Cooled Generator

ITEMS	Parts Number	DESCRIPTION	QTY	REMARK
1		Canopy right side support	1	
2		Right hinge	1	
3		Frontboard	1	
4		MS816-1A-1lock	1	
5		Water port	1	
6		Top cover	4	
7		Water port support	1	
8		Left hinge	1	
9		Stand column 1	1	
10		Sideboard 1	1	
11		R Stand column2	1	
12		Stainless steel board	1	
13		Board left support	1	
14		Sideboard 2	1	
15		Back board	1	
16		Base subassembly	1	
17		Output terminal	1	
18		Alternator waterproof board	1	
19		Sideboard 3	1	
20		Emergency stop switch shield	1	
21		Emergency stop switch	1	
22		Sideboard 4	1	
23		R Stand column 3	1	

## Common Formulas

Items	Unit	Name	Conversion
Power	kW	kilowatt	1 kilowatt= 1.36 horsepower (1kW = 1.36Ps)
Torsion	N·m	Newton · meter	1 kilogram· meter = 9.81 Newton · meter (1kgf·m = 9.81N·m)
Speed	r/min	rotate/minute	
Oil, fuel, consumption	g/kW·h	gram/kilowatt-hour	1gram/horsepower hour = 1.36 Gram/kilowatt-hour (1g/Ps·h) = 1.36g/kW·h)
Capacity(L)	l	liter	1 liter = 1000milliliter (1L=1000ml)
Acreage	cm <sup>2</sup>	square centimeter	1 square meter = 10000 square centimeter (1m <sup>2</sup> = 10000cm <sup>2</sup> )
Pressure	KPa MPa	kilopascal mega-pascal	1kilogram force/square centimeter = 98.1 kilopascal = 0.0981 mega-pascal (1kgf/cm <sup>2</sup> = 98.1kPa = 0.0981Mpa)
Power	N	Newton	1-kilogram force= 9.8Newton (1kgf = 9.8N)
Length	m	meter	1meter= 1000millimeter (1m = 1000mm)
Time	min(s)	minute(second)	1minute = 60second (1min = 60s)
Temperature	K(°C)	Kelvin degree (centigrade)	273K = 0°C
Voltage	V	volt	
Current	A	ampere	
Crankshaft Angle	°CA	angle, crankshaft angle	
Quality	g	gram	1 kilogram =1000g (1kgf.m=9. 81N.m)

### Common Maintenance Parts for Generator

Item	Name	SPEC.	Unit	Quality	Note
1	Charge motor	12V70ADC	PC	1	
2	Start motor	QDY112	PC	1	
3			PC	1	
4	Carbon brush	L65	PC	1	
5	Water pump belt	4PK-760	PC	1	
			PC	1	
			PC	1	
			PC	1	
			PC	1	
			PC	1	
6	Manifold inlet pad	465Q	PC	1	
7	Exhaust manifold pad	465Q-1	PC	1	
8	Ignition coil	465QR	PC	1	
9	Crankshaft position sensor	465Q5	PC	1	
10	Water temperature switch	100°C	PC	1	
11	Solenoid valve	QRY-4	PC	1	
12	Gas valve	HODH-LKN	SET	1	
13	Fan		PC	1	Outer annulus size (Φ375)
14	Radiator	LD465	PC	1	
15	Mixer assembly	015A0372	PC	1	
16	ETC		SET	1	
17	Air filter	K1330	PC	1	
18	Air filter pipe	Φ50-Φ65	PC	1	
19	Oil filter spanner	HM-501	PC	1	
20	Spark plug socket	L114	SET	1	
21	Spark plug	K6RTC	PC	4	
22	Universal wheel	Φ125-32	PC	2	
23	Directional wheel	Φ125-32	PC	2	
24	Foot support		PC	4	
25	Temperature control	45°C, 90°C	PC	1	
26	Heating pipe	500W AC220V	PC	1	
27	Waste pipe	015A0370	PC	1	
28	Wire harness		SET	1	
29	ECU	20KW/120V/240V	PC	1	
30	Control panel	HSC940	PC	1	

### Additional Troubleshooting Procedures

1. Simple check
2. Battery voltage, working voltage.
3. Sufficient fuel supply – check that the fuel valve is open?
4. Is the entrance and pressure reducer to gas solenoid valve properly open?
5. High voltage normal or not: spark plug).
6. Speed sensors signal normal or not.
7. Observe exhaust gas (color, smell, sound and feel).
8. Replace the suspected parts only with new certified genuine parts, then observe operation.
9. If a fault is repaired, then observe the start and listen to the engine.
10. If the fault appears again, verify that genuine parts are being used and properly installed.

### Common Faults and Repair Methods of Genset

#### Perform the following methods:

1. Basic check:
2. Make sure the unit is filled with engine oil.
3. Make sure the unit is filled with enough coolant.
4. Make sure the gas valve is open. Check for suitable gas pressure.
5. Check whether the battery is sufficiently charged or not.
6. Check the main power input when starting the unit automatically.
7. Check the power indicator light on the digital controller to make sure it's on.
8. Check Gas flow pressure: turn the transition nut on pressure regulator to adjust proper gas flow.
9. Battery voltage test: use a multi-meter to test the battery voltage, if voltage is 12.6 V, battery has enough power; if voltage is below 12.6V, recharge battery.
10. Cylinder wire check: see picture below, the gap between the conductor and engine is 3-5mm, start the start motor, check for spark.

- Spark plug check: contact spark plug with engine block. Initiate starter motor, observe whether the spark plug is sparking to the ground contact on engine block. If no spark, replace plug.



- Igniter test: use a multi-meter to test the socket voltage, it should read 12V

Test 1, 2 and 2, 3 two pile heads voltage cycle 12V

- Check starter motor: when generator exercises initial start, the main shaft of the Starter motor should engage and rotate substantially open throttle. If the starter motor is not working properly, replace the starter.



### Generator hunting elimination:

After starting generator, if there is too much irregular pattern vibration, this means generator is hunting (frequency fluctuation  $>2\text{Hz}$ ). The power output produced while hunting will not influence the use of electricity (except with high precision digital equipment, which requires Low harmonic distortion and high-quality electric frequency). Still, this should be adjusted and repaired promptly.

1. General checking:
2. Check whether the gas pressure is normal or not.
3. Check whether the fuel line is blocked.
4. Check whether the speed sensor is loose or damaged.
5. Check starter.
6. Measuring method:
7. Connect a pressure meter in the inlet pipe, open the gas valve, observe the data on pressure gauge.
8. Observe whether the gas valve is extruded or not.
9. Open the fuel switch; see if there is a hum from the solenoid valve.
10. Use the multi-meter Ohm level, measure the two joints of the speed sensor, and there should be resistance.
11. Check whether the electrical speed regulation has 12v DC power input.

### No Power Output: Troubleshooting

After starting the generator, there is no power output under the right speed and frequency, perform the following steps to check and solve issues:

- Check whether the battery has enough voltage (Voltage  $>12\text{V}$ ).
- Check circuit for proper voltage input and output.
- Connect the voltage regulator and battery, and check whether the regulator and battery have the same voltage input.
- When the generator operates normally, the carbon brush should have approximately 70 volts.

*Measuring method:*

- Use the multi-meter 20V DC to measure the voltage of battery and voltage regulator input.
- Use the multi-meter 200V DC to measure the voltage of the carbon brush.

*Repair method:*

When the voltage regulator has input but no output, there may be two possible reasons, (output short circuit protection, secondary winding protection). Cut power, discharge regulator and reconnect. The common protection time is 90 seconds, but under abnormal conditions it will take about 1 hour.



**Address**

4480 Av. des Industries, Laval, QC H7C 1A2

**Phone**

(514) 863-7097

**Email**

[info@solarelios.com](mailto:info@solarelios.com)

**Website**

[www.solarelios.com](http://www.solarelios.com)